



# 8B49

## Voltage Output Modules

### Description

8B modules are an optimal solution for monitoring real-world process signals and providing high-level signals to a data acquisition system. Each 8B49 module accepts an input signal from a non-isolated source, then isolates, filters and converts the signal to a high-level process voltage output (Figure 1).

Signal filtering is accomplished with a 4-pole filter optimized for time and frequency response which provides 80dB per decade of normal-mode rejection above 100Hz. One pole of this filter is on the system side and the other three are on the isolated field side.

A special output circuit in the 8B49 module provides protection against accidental connection of power-line voltages up to 40VAC continuous. Clamp circuits on the I/O and power terminals protect against harmful transients.

The modules are designed for installation in Class I, Division 2 hazardous locations and have a high level of immunity to environmental noise.

### ► Features

- Accepts High-Level Voltage
- Isolated Process Voltage Output
- 1500Vrms Isolation
- ANSI/IEEE C37.90.1 Transient Protection
- Output Protection to 40VAC Continuous
- 110dB CMR
- 100Hz Signal Bandwidth
- ±0.05% Accuracy
- ±0.02% Linearity
- Low Drift with Ambient Temperature
- C-UL-US Listed
- CE Compliant
- ATEX Compliance Pending
- Mix and Match Module Types on Backpanel

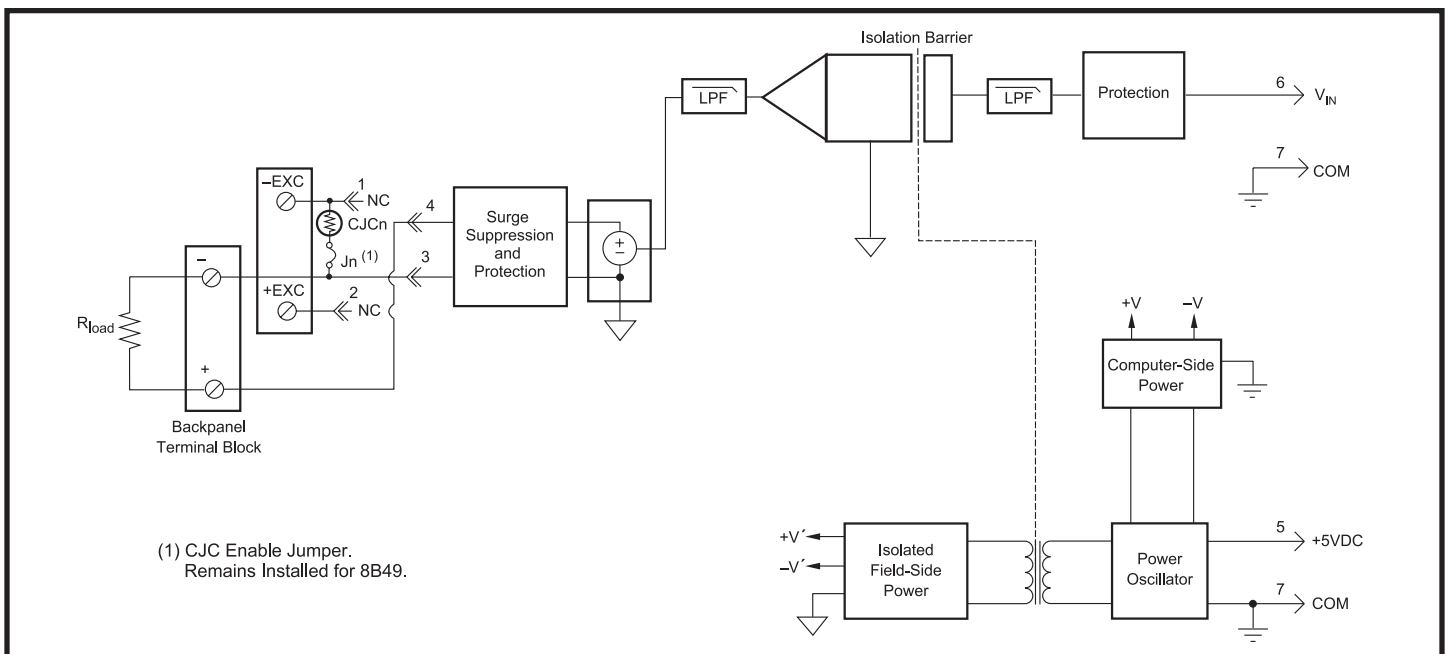

(1) CJC Enable Jumper. Remains Installed for 8B49.

Figure 1: 8B49 Block Diagram

**Specifications** Typical\* at T<sub>A</sub>=+25°C and +5VDC power

Module	8B49
Input Voltage Range	±5V, 0 to +5V, ±10V, 0 to +10V
Input Voltage Maximum	±20V (no damage)
Input Resistance	≥1MΩ
Output Voltage Range	±5V, 0 to +5V, ±10V, 0 to +10V
Over Range Capability	5% at 10V output
Output Drive	±20mA max
Output I Under Fault, max	30mA
Output Protection	40VAC max
Continuous	ANSI/IEEE C37.90.1
Transient	
CMV, Output to Input	1500Vrms max
Continuous	ANSI/IEEE C37.90.1
Transient	110dB
CMR (50 or 60Hz)	80dB per decade above 100Hz
NMR (-3dB at 100Hz)	
Accuracy <sup>(1)</sup>	±0.05% Span (0 to 10mA Load) ±0.075% Span (10 to 20mA Load)
Linearity	±0.02% Span
Stability	
Offset	±10ppm/°C
Gain	±50ppm/°C
Noise	
Output, 100kHz	800μVrms
Bandwidth, -3dB	100Hz
Response Time, 90% Span	5ms
Power Supply Voltage	+5VDC ±5%
Power Supply Current	100mA Full Load, 30mA No Load
Power Supply Sensitivity	±100ppm/%
Mechanical Dimensions (h)(w)(d)	1.11" x 1.65" x 0.40" (28.1mm x 41.9mm x 10.2mm)
Environmental	
Operating Temp. Range	-40°C to +85°C
Storage Temp. Range	-40°C to +85°C
Relative Humidity	0 to 95% Noncondensing
Emissions EN61000-6-4	ISM, Group 1
Radiated, Conducted	Class A
Immunity EN61000-6-2	ISM, Group 1
RF	Performance A ±0.5% Span Error
ESD, EFT	Performance B

**NOTES:**

\* Contact factory or your local Dataforth sales office for maximum values.

(1) Includes linearity, hysteresis and repeatability.

**Ordering Information**

Model	Input Range	Output Range
8B49-01	0V to +5V	-5V to +5V
8B49-02	-5V to +5V	-5V to +5V
8B49-03	-5V to +5V	0V to +5V
8B49-04	0V to +10V	-10V to +10V
8B49-05	-10V to +10V	-10V to +10V
8B49-06	-10V to +10V	0V to +10V
8B49-07	-5V to +5V	-10V to +10V