

Seal/O OEM User Manual

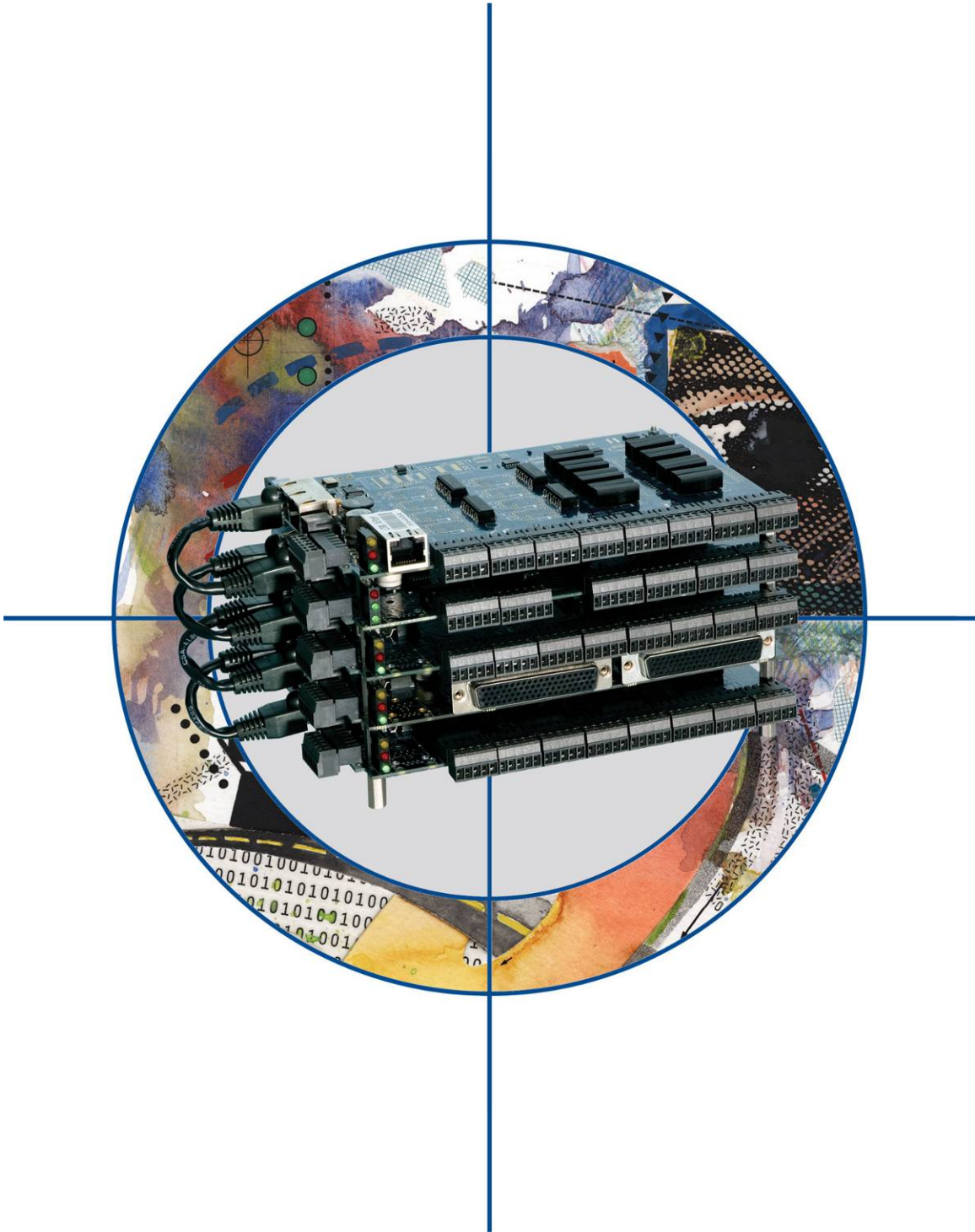

SEALEVEL
SYSTEMS INCORPORATED

Table of Contents

INTRODUCTION.....	1
BEFORE YOU GET STARTED.....	3
WHAT'S INCLUDED.....	3
SEAI/O HARDWARE DESCRIPTION.....	4
SEAI/O BASE AND EXPANSION MODULES.....	4
SEAI/O MODULE COMMON FEATURES	5
SEAI/O CONFIGURATIONS & SPECIFICATIONS	6
410 Series – 16 Optically Isolated Inputs/16 Reed Relay Outputs.....	6
420 Series – 16 Optically Isolated Inputs/8 Form C Outputs.....	7
430 Series – 32 Optically Isolated Inputs.....	8
440 Series – 32 Reed Relay Outputs.....	9
450 Series – 16 Form C Relay Outputs	10
462 Series – 96 Channel TTL DB-78.....	11
463 Series – 96 Channel TTL 50-Pin.....	13
470 Series – 16 A/D, 2 D/A, 8 24V Outputs, 8 Isolated Inputs.....	16
520 Series – 8 Optically Isolated Inputs/8 High-Current Form C Outputs.....	17
POWER OPTIONS	18
BASE MODULE POWER CONNECTION.....	18
SEAI/O EXPANSION POWER CONNECTION	18
SEAMAX APPLICATION SUITE	20
SEAMAX OVERVIEW	20
COMMUNICATING VIA MODBUS	21
SEAMAX SOFTWARE INSTALLATION	22
MAXSSD CONFIGURATION & DIAGNOSTICS UTILITY	23
TROUBLESHOOTING SEAMAX.....	34
HARDWARE CONFIGURATION	36
DEVICE ADDRESS CONFIGURATION	36
CONFIGURING THE “BASE” SEAI/O MODULE.....	38
CONFIGURING N-SERIES EXPANSION MODULES	39
CONFIGURING AN ETHERNET MODULE (E-SERIES).....	40
SEAI/O-470 JUMPER AND DIPSWITCH SETTINGS.....	43
WIRING OPTIONS	45
SEAI/O PASS-THROUGH CONNECTOR	45
I/O WIRING – SEAI/O-410, 420, 430, 440, AND 450 MODULES	46
I/O WIRING – SEAI/O-462 AND 463 MODULES	47
I/O WIRING – SEAI/O-470 MODULES	50
I/O WIRING – SEAI/O-520 MODULES	53
CONNECTOR PIN OUTS.....	54
ACCESSORIES	55

APPENDIX A – HOW TO GET ASSISTANCE 57
APPENDIX B – CAD DRAWING 58
APPENDIX C – COMPLIANCE NOTICES 59
 FEDERAL COMMUNICATIONS COMMISSION STATEMENT 59
WARRANTY..... 60

Introduction

Seal/O™ OEM modules provide a powerful way to add I/O to a variety of computers, controllers, and PLCs. Each Seal/O board model is designed for maximum flexibility and easy field wiring. Ordering options allow connection to the host device via Wireless 802.11b/g (Coming Soon!), Ethernet, USB, RS-485, or RS-232, and multiple units can be daisy chained together using convenient pass-through connectors. For easy software integration, application programs or 3rd party software can use the Sealevel SeaMAX™ library or industry standard Modbus protocol.

This manual covers the installation and operation of these SeaI/O products:

Ethernet



Ethernet 10/100 BaseT

Seal/O-410E – 16 Optically Isolated Inputs/16 Reed Relay Outputs
Seal/O-420E – 16 Optically Isolated Inputs/8 Form C Outputs
Seal/O-430E – 32 Optically Isolated Inputs
Seal/O-440E – 32 Reed Relay Outputs
Seal/O-450E – 16 Form C Relay Outputs
Seal/O-462E – 96 Bit TTL I/O (DB-78)
Seal/O-463E – 96 Bit TTL I/O (50-Pin IDC)
Seal/O-470E – 8 Inputs/8 Outputs/2 D/A & 16 A/D
Seal/O-520E – 8 Optically Isolated Inputs/8 High-Current Form C Outputs

USB



USB

Seal/O-410U – 16 Optically Isolated Inputs/16 Reed Relay Outputs
Seal/O-420U – 16 Optically Isolated Inputs/8 Form C Outputs
Seal/O-430U – 32 Optically Isolated Inputs
Seal/O-440U – 32 Reed Relay Outputs
Seal/O-450U – 16 Form C Relay Outputs
Seal/O-462U – 96 Bit TTL I/O (DB-78)
Seal/O-463U – 96 Bit TTL I/O (50-Pin IDC)
Seal/O-470U – 8 Inputs/8 Outputs/2 D/A & 16 A/D
Seal/O-520U – 8 Optically Isolated Inputs/8 High-Current Form C Outputs

RS-485

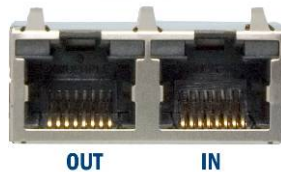

RS-485

Seal/O-410M – 16 Optically Isolated Inputs/16 Reed Relay Outputs
Seal/O-420M – 16 Optically Isolated Inputs/8 Form C Outputs
Seal/O-430M – 32 Optically Isolated Inputs
Seal/O-440M – 32 Reed Relay Outputs
Seal/O-450M – 16 Form C Relay Outputs
Seal/O-462M – 96 Bit TTL I/O (DB-78)
Seal/O-463M – 96 Bit TTL I/O (50-Pin IDC)
Seal/O-470M – 8 Inputs/8 Outputs/2 D/A & 16 A/D
Seal/O-520M – 8 Optically Isolated Inputs/8 High-Current Form C Outputs

RS-232



RS-232

Seal/O-410S – 16 Optically Isolated Inputs/16 Reed Relay Outputs
Seal/O-420S – 16 Optically Isolated Inputs/8 Form C Outputs
Seal/O-430S – 32 Optically Isolated Inputs
Seal/O-440S – 32 Reed Relay Outputs
Seal/O-450S – 16 Form C Relay Outputs
Seal/O-462S – 96 Bit TTL I/O (DB-78)
Seal/O-463S – 96 Bit TTL I/O (50-Pin IDC)
Seal/O-470S – 8 Inputs/8 Outputs/2 D/A & 16 A/D
Seal/O-520S – 8 Optically Isolated Inputs/8 High-Current Form C Outputs

Expansion Units (Connect to Base Unit via RS-485)

Seal/O-410N – 16 Optically Isolated Inputs/16 Reed Relay Outputs
Seal/O-420N – 16 Optically Isolated Inputs/8 Form C Outputs
Seal/O-430N – 32 Optically Isolated Inputs
Seal/O-440N – 32 Reed Relay Outputs
Seal/O-450N – 16 Form C Relay Outputs
Seal/O-462N – 96 Bit TTL I/O (DB-78)
Seal/O-463N – 96 Bit TTL I/O (50-Pin IDC)
Seal/O-470N – 8 Inputs/8 Outputs/2 D/A & 16 A/D
Seal/O-520N – 8 Optically Isolated Inputs/8 High-Current Form C Outputs

Overview

Sealevel SeaI/O OEM modules are available in various I/O configurations, each designed for maximum flexibility and easy field wiring. Host devices can communicate with SeaI/O OEM modules using Modbus TCP (Ethernet) or Modbus RTU (RS-232, RS-485, and USB). Up to 246 expansion modules can be daisy chained together via RS-485 using convenient pass-through connectors. Coupled with the SeaMAX Suite, Sealevel SeaI/O OEM modules offer powerful data acquisition solutions that are perfect for a wide range of applications and environments with easy interfacing to computers, controllers, and PLCs.

Industry Segments

SeaI/O OEM modules are perfect for a wide variety of applications and environments including:

- Process Control
- Data Acquisition
- Broadcast Automation
- Security
- Facility Management

Features

- Choice of Connectivity:
 - Wireless (802.11b/g) – coming soon!
 - Ethernet
 - USB
 - RS-485
 - RS-232
- Supports Industry Standard Modbus TCP & RTU Protocols
- Models Offering Choice of:
 - Optically Isolated Inputs
 - Reed Relay Outputs
 - Form C Relay Outputs
 - TTL Interfaces
 - Analog A/D & D/A
- Status Indicator LEDs for Communication, Fault, and Status
- Field Removable Terminal Block Connectors (most models)
- 9-30VDC Power Input
- Power Input via Terminal Block or DC Jack
- Daisy Chain up to 247 Modules
- Metal Standoffs Allow Variety of Mounting Options
- Extended Temperature Available (-40°C to +85°C)
- Compact Size - 7.5"(L) x 5.0"(W) x 0.8"(H)

Before You Get Started

What's Included

All Sea/O OEM modules are shipped with the following items. If any of these items is missing or damaged please contact Sealevel for a replacement.

- Sea/O OEM Board – Data Acquisition Module
- Sealevel SeaMAX Software CD
- (4) ¾” Metal Standoffs with Nuts
- Accessories (Model Dependent)

	<p>NOTE: Depending on the interface type, your Sea/O OEM module may include additional accessories, which are listed below.</p> <p>Additional useful items can be found in the Accessories section on this manual.</p>
---	--

Included Communications and Expansion Accessories

Sea/O OEM modules are shipped with the following accessories:

E-Series (Ethernet)	Item# CA246 – 1 x 7’ straight through Ethernet cable, for connection to a hub or switch. Item# CA251 – 1 x 7’ crossover cable, for direct connection to a computer’s Ethernet port. DO NOT connect the yellow crossover cable to the RJ45 RS-485 pass-through connectors on the left side of the Sea/O module!
U-Series (USB)	Item# CA179 – 6’ A to B USB cable.
M-Series (RS-485)	No cable is included. RS-485 twisted-pair wiring connects to screw terminals.
S-Series (RS-232)	Item# KT119 – RS-232 DB9/RJ45 Kit, includes a DB9F to RJ45 adapter with RS-232 pinout (Item# DB109) and a 7’ CAT5 patch cable (Item# CA246) for connecting Sea/O OEM modules to both Sealevel and standard RS-232 serial ports.
N-Series (Expansion)	CA239 – 5” CAT5 RS-485 interconnect cable, for connecting two or more Sea/O boards together in a “stack”.
All Models	Each Sea/O OEM module is shipped with four (4) ¾” metal standoffs and nuts, which provides a variety of mounting options in custom enclosures.

Seal/O Hardware Description

Seal/O Base and Expansion Modules

Base OEM modules connect to the host via one of the following interfaces:

- E-Series - Ethernet Modbus TCP
- U-Series - USB Modbus RTU
- M-Series - RS-485 Modbus RTU
- S-Series - RS-232 Modbus RTU

After the Base unit is installed, up to 246 additional Seal/O **N-Series Expansion Modules** can be added to create an I/O network. These expansion modules interface via RS-485 and can be located local to the Base Seal/O device or remotely located up to 4000 feet away. Local installations should use the 5" CAT5 RS-485 pass-through cable (Item# CA239) shipped with each N-series module to connect. Remote expansion modules should use RS-485 twisted pair wiring from the Base unit connected via the removable screw terminal connector.

For local installations power to the expansion modules is supplied from the Base unit via the pass-through connectors. For remote devices, separate power is required at each expansion unit. Refer to the **Power Options** section of this manual for more information on Seal/O power requirements and power supply sizing.

Seal/O Module Common Features

All Seal/O OEM modules include the same connectors and configuration options on the side of the unit:

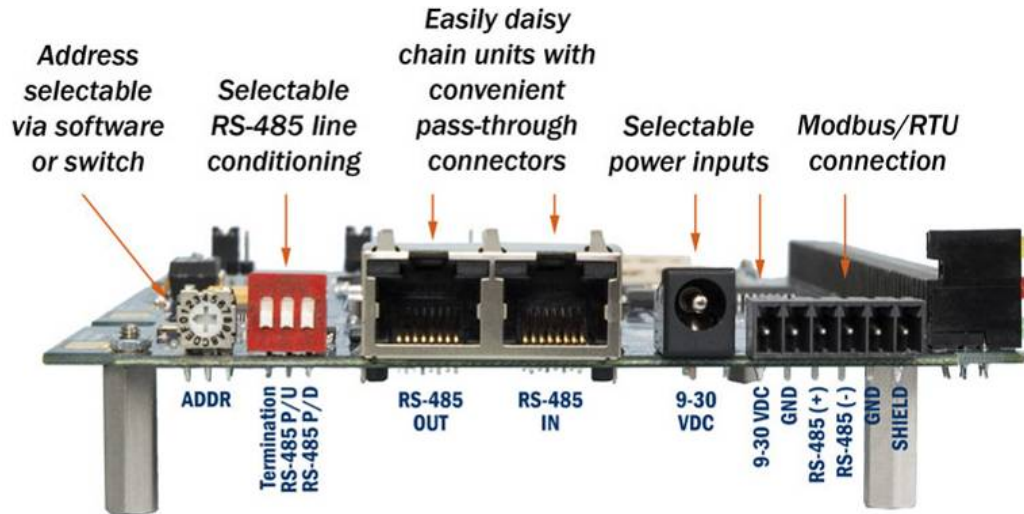

NOTE: RS-485 networks should have termination enabled on each end of the network. Pull-up and pull-down resistors should also be enabled on the last device on the network.



The 9-30VDC input barrel connector is center positive.

Status LEDs are also included on the front of all Seal/O OEM modules to indicate the following information:

- Communication (Yellow) – Blinks when data is transmitted
- Fault (Red) – Lights when there is a problem with the device
- Status (Green) – See **Device Address Configuration** section of this manual
 - Blinks when the rotary “ADDR” switch is set to “0” and the default Slave ID is set to 247
 - Lights steady when module is properly configured from the factory defaults



Seal/O Configurations & Specifications

410 Series – 16 Optically Isolated Inputs/16 Reed Relay Outputs

Seal/O-410 modules provide 16 optically isolated inputs and 16 Reed relay outputs. Inputs can range from 5-30VDC, while the Reed relays provide long life switch closures that are well suited for low current applications. Inputs and outputs are grouped into four-bit segments. Each group shares a common for easy wiring via removable 3.5mm terminal blocks. (Ethernet version shown)



Inputs

Type:	16 non-polarized optically isolated inputs
Voltage Range:	5-30VDC
Isolation:	300V
Input Resistance:	6.2K Ohms in series
Response Time:	4 microseconds

Outputs

Type:	16 SPST Form A Reed relays
Power:	10VA max.
Contact Voltage:	60VDC max.
Contact Current:	500mA max.
Operate Time:	0.5ms max.
Bounce Time:	0.5ms max.
Release Time:	0.2ms max.

420 Series – 16 Optically Isolated Inputs/8 Form C Outputs

The SeaI/O-420 provides 16 optically isolated inputs and 8 SPDT Form C relay outputs. Inputs can range from 5-30VDC and provide 300V isolation to ground. Each output offers normally open and normally closed contact connections via 3.5mm field removable terminal blocks. (USB version shown)



Inputs

Type:	16 non-polarized optically isolated inputs
Voltage Range:	5-30VDC
Isolation:	300V
Input Resistance:	6.2K Ohms in series
Response Time:	4 microseconds

Outputs

Type:	8 SPDT Form C relays
Power:	DC 30W/ AC 60 VA
Contact Voltage:	60VDC max.
Contact Current:	2A max.
Operate Time:	2ms max.
Bounce Time:	7ms max.
Release Time:	1ms max.

430 Series – 32 Optically Isolated Inputs

Seal/O-430 modules provide 32 optically isolated inputs with 300V external isolation and high channel-to-channel isolation. Ideal for low voltage monitoring applications, connection to real world signals is made via 3.5mm convenient removable screw terminal connectors. (RS-232 version shown)

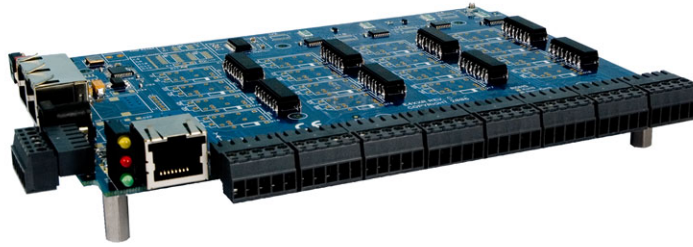

Inputs

Type:	32 non-polarized optically isolated inputs
Voltage Range:	5-30VDC
Isolation:	300V
Input Resistance:	6.2K Ohms in series
Response Time:	4 microseconds

440 Series – 32 Reed Relay Outputs

The SeaI/O-440 provides 32 SPST Form A dry contact Reed relays. Reed relays offer long life performance and fast response time. Convenient removable 3.5mm screw terminal blocks compatible with 14-22 AWG wiring allow reliable connection to real world I/O. (RS-485 version shown)



Outputs

Type:	32 SPST Form A Reed relays
Power:	10VA max.
Contact Voltage:	60VDC max.
Contact Current:	500mA max.
Operate Time:	0.5ms max.
Bounce Time:	0.5ms max.
Release Time:	0.2ms max.

450 Series – 16 Form C Relay Outputs

Control a variety of low voltage, low current devices with the SeaI/O-450. The module's 16 channels of highly reliable SPDT Form C relay outputs are rated for up to 60VDC @ 2A. Each output offers normally open and normally closed contact connections via 3.5mm field removable terminal blocks. (Ethernet version shown)



Outputs

Type:	16 SPDT Form C relays
Power:	DC 30W/ AC 60 VA
Contact Voltage:	60VDC max.
Contact Current:	2A max.
Operate Time:	2ms max.
Bounce Time:	7ms max.
Release Time:	1ms max.

462 Series – 96 Channel TTL DB-78

Perfect for driving industry-standard solid-state relay (SSR) racks, the SeaI/O-462 provides 96 bits of buffered drive TTL I/O. Each DB-78 connector brings out 48 I/O bits addressable as six, eight-bit ports. For easy connection to relay racks, Sealevel offers a six-foot cable (Item# CA237) that terminates each DB-78 connector to two industry standard 50-pin IDC connectors. Order part number 462x-KT and receive two CA237 cables with each unit. (RS-485 version shown)



Power Requirements

Max Output Power: +5VDC @ 1A (5W)

Inputs

Logic High: Min 2VDC
Logic Low: Max 0.8VDC

Outputs

Logic High: Max 0.5VDC @ 64mA
Logic Low: Min 2VDC @ 32mA

NOTE: The SeaI/O-462 modules are designed to work with industry standard solid-state relay racks that expect negative logic to operate. The SeaI/O-462 modules expect positive logic on the inputs.



Seal/O-462 Optional Items

Depending upon your application, you are likely to find one or more of the following items useful for interfacing the Seal/O-462 to real-world signals. All items can be purchased from our website (<http://www.sealevel.com>) or by calling 864-843-4343.

For high-current, high-voltage applications:

- DB-78 to Dual IDC 50 Pin Ribbon Cable (Item Number **CA237**)
 - 60” cable connects each Seal/O-462’s DB-78 connectors to solid-state relay racks equipped with 50-pin header interface.
- Solid-State Relay Racks:
 - Quad six position relay rack (Part Number **PB24HQ**)
 - Relay rack can accept up to six QSSRs for a total of 24 channels. Features a 50-pin header connector for easy interface via 50-conductor ribbon cables.
 - Quad four position relay rack (Part Number **PB16HQ**)
 - Relay rack can accept up to four QSSRs for a total of 16 channels. Features a 50-pin header connector for easy interface via 50-conductor ribbon cables.
- Quad Solid-State Relay Modules:
 - AC Input (Part Number **IA5Q**) – Provides 4 channels of discrete I/O interface to monitor AC inputs up to 140V @ 10mA.
 - DC Input (Part Number **IB5Q**) – Provides 4 channels of discrete I/O interface to monitor DC inputs from 3.3V to 32V.
 - AC Output (Part Number **OA5Q**) – Provides 4 channels of discrete I/O interface to control AC outputs up to 140V @ 3A.
 - DC Output (Part Number **OB5Q**) – Provides 4 channels of discrete I/O interface to control DC outputs up to 60V @ 3A.
- Simulation/debug module (Part Number TA01)
 - Module simulates the operation and load characteristics of a standard 24-channel relay rack. An LED corresponding to each port bit illuminates to indicate state. Eight position DIP-switches are used to generate input status changes.

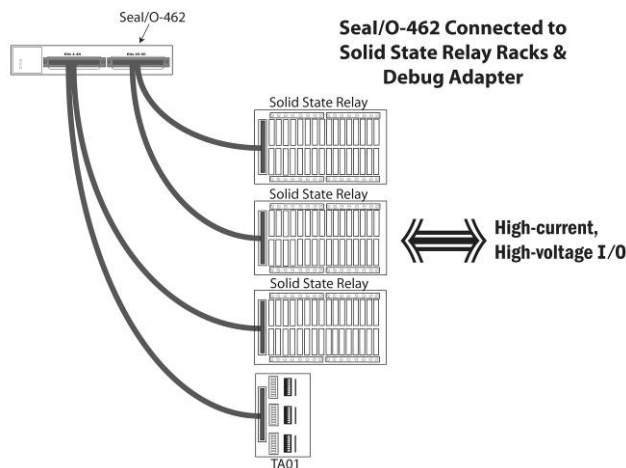

463 Series – 96 Channel TTL 50-Pin

The SeaI/O-463 offers 96 bits of buffered drive TTL I/O via four internal industry-standard 50-pin header connectors. The interface module addresses the 96 channels of I/O as 12 eight-bit ports, each programmable as input or output. Using standard 50-pin IDC ribbon cables, connect up to four industry standard relay racks for PC based control and automation of equipment including sensors, switches, security control systems, and other industrial automation systems. A metal strain relief bracket is included to secure the cables after installation. (RS-485 version shown)

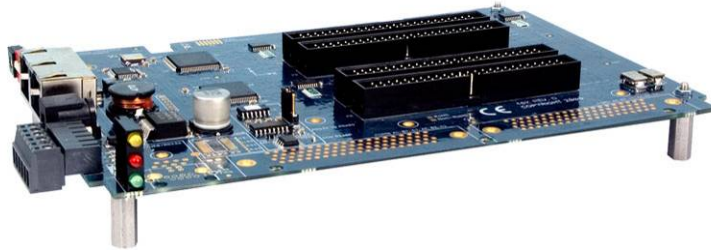

Power Requirements

Max Output Power: +5VDC @ 1A (5W)

Inputs

Logic High: Min 2VDC
Logic Low: Max 0.8VDC

Outputs

Logic High: Max 0.5VDC @ 64mA
Logic Low: Min 2VDC @ 32mA

NOTE: The SeaI/O-463 modules are designed to work with industry standard solid-state relay racks that expect negative logic to operate. The SeaI/O-463 modules expect positive logic on the inputs.



Seal/O-463 Optional Items

Depending upon your application, you are likely to find one or more of the following items useful for interfacing the Seal/O-463 to real-world signals. All items can be purchased from our website (<http://www.sealevel.com>) or by calling 864-843-4343.

For TTL applications:

- Terminal Block Kit - (Item# **KT107**)
 - Kit includes the TB07 screw terminal block and CA167 ribbon cable for connecting one of the Seal/O-463's 50-pin header connectors to your I/O. 6" Snap track and DIN rail clips are included for DIN rail mounting.
- IDC 50 to IDC 50 Pin 40" Ribbon Cable (Item# **CA167**)
 - Interfaces each of the Seal/O-463's 50-pin header connectors.
- Simulation/debug module (Item# **TA01**)
 - Module allows monitoring status of output pins and controlling state of input pins. An LED corresponding to each port bit illuminates to indicate state. Eight position DIP-switches are used to generate input status changes.

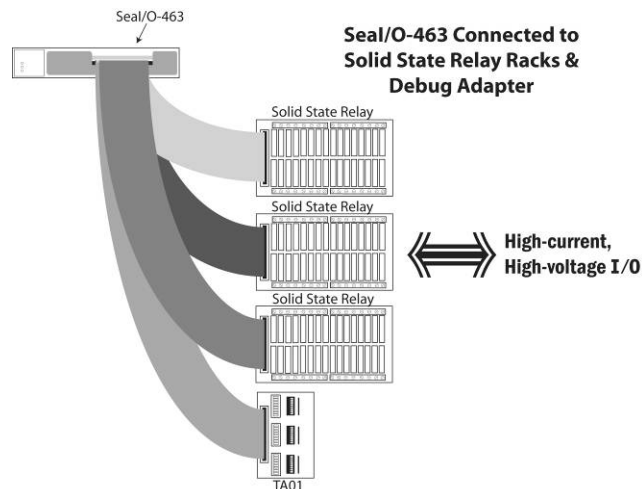

For high-current, high-voltage applications:

- IDC 50 to IDC 50 Pin Ribbon Cable (Item# **CA167**)
 - 40” cable connects the Seal/O-463 to solid-state relay racks equipped with 50-pin header interface.
- IDC 50 to IDC 50 Pin Ribbon Cable (Item# **CA135**)
 - 40” cable connects the Seal/O-463 to solid-state relay racks equipped with 50-pin edge connector.
- Solid-State Relay Racks:
 - Quad six position relay rack (Item# **PB24HQ**)
 - Relay rack can accept up to six QSSRs for a total of 24 channels. Features a 50-pin header connector for easy interface via 50-conductor ribbon cables.
 - Quad four position relay rack (Item# **PB16HQ**)
 - Relay rack can accept up to four QSSRs for a total of 16 channels. Features a 50-pin header connector for easy interface via 50-conductor ribbon cables.
- Quad Solid-State Relay Modules:
 - AC Input (Item# **IA5Q**) – Provides 4 channels of discrete I/O interface to monitor AC inputs up to 140V @ 10mA.
 - DC Input (Item# **IB5Q**) – Provides 4 channels of discrete I/O interface to monitor DC inputs from 3.3V to 32V.
 - AC Output (Item# **OA5Q**) – Provides 4 channels of discrete I/O interface to control AC outputs up to 140V @ 3A.
 - DC Output (Item# **OB5Q**) – Provides 4 channels of discrete I/O interface to control DC outputs up to 60V @ 3A.
- Simulation/debug module (Item# **TA01**)
 - Module simulates the operation and load characteristics of a standard 24-channel relay rack. An LED corresponding to each port bit illuminates to indicate state. Eight position DIP-switches are used to generate input status changes.

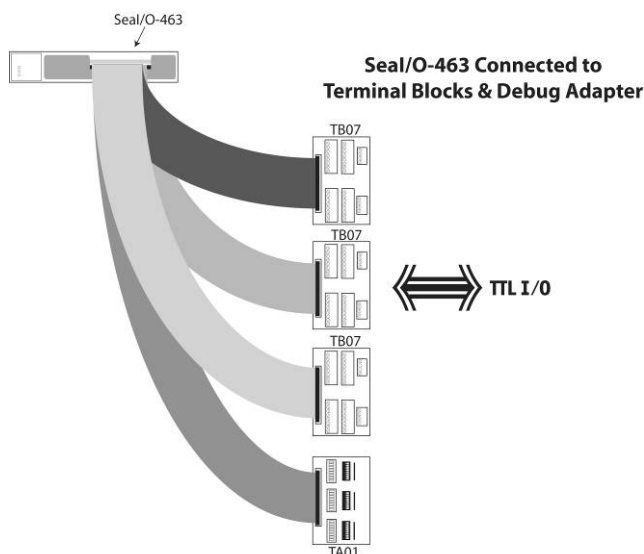

470 Series – 16 A/D, 2 D/A, 8 24V Outputs, 8 Isolated Inputs

Designed using the Maxim MAX197 successive approximation-type A/D chip, the Seal/O-470 provides eight differential or 16 single-ended 12-bit inputs. The A/D inputs can be individually configured for sensing 4-20mA current loop signals. Additionally, the module provides two 12-bit D/A output channels, eight optically isolated inputs, and eight open collector outputs, ideal for driving 24V devices commonly found in industrial environments. Perfect for a variety of data acquisition/control and test & measurement applications, the Seal/O-470 includes removable screw terminals, which simplify field-wiring connections.

(RS-232 version shown)

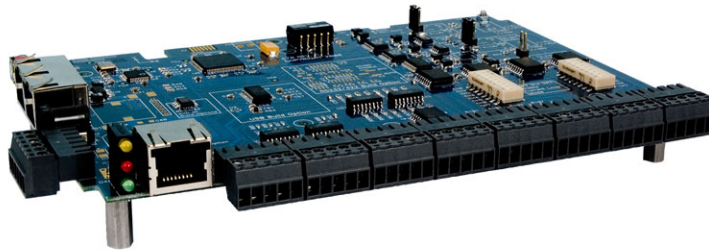

Optically Isolated Inputs

Input Range: 5-30VDC

Open Collector Outputs

Output Voltage: Max. 30VDC

Output Current: Max. 500mA (single output)

Output Current: Max. 580mA (all outputs)

A/D Inputs

Number of Channels: 8 differential or 16 single-ended

Resolution: 12-bits

Sampling Rate: 100K/s

A/D Input Range

Software Selectable: 0-5V, 0-10V, +/-5V, +/-10V

Hardware Selectable: 0-20mA current loop (for 4-20mA devices)

D/A Outputs

Number of Channels: 2 single-ended

Resolution: 12-bits

Output Range: 0-5V, 0-10V

Load Resistance: Min. 2K

520 Series – 8 Optically Isolated Inputs/8 High-Current Form C Outputs

The SeaI/O-520 provides 8 optically isolated inputs and 8 SPDT high-current Form C relay outputs. Inputs can range from 5-30VDC and provide 300V isolation to ground. Each output offers normally open and normally closed contact connections via 3.5mm field removable terminal blocks. (USB version shown)



Inputs

Type:	8 non-polarized optically isolated inputs
Voltage Range:	5-30VDC
Isolation:	300V
Input Resistance:	6.2K Ohms in series
Response Time:	4 microseconds

Outputs

Type:	8 SPDT High-Current Form C relays
Contact Voltage:	250VAC/60VDC max.
Contact Current (AC):	6A max.
Contact Current (DC):	<30 VDC @5A max./ >30 VDC @500mA max.
Switching Capacity:	5 VDC @ 100mA min.
Operate Time:	10ms max.
Release Time:	10ms max.

Power Options

Base Module Power Connection

Base modules are powered from a 9-30VDC source using either the DC jack or screw terminals on the side of the unit. Sealevel offers several power supply choices to make connection easy (see Accessories chapter at the end of this document).

Seal/O Expansion Power Connection

Each Seal/O product, including the expansion modules, contains an onboard switching regulator power supply rated for 9-30VDC. For local installations (less than 10' apart), expansion unit power is usually supplied from the Base unit via the pass-through connectors. The number of expansion modules that can be driven from the Base unit depends on the power source and number/type of expansion units. Refer to the chart below for power requirements. For expansion modules mounted remotely (greater than 10' apart), separate power is required at each expansion unit.

Seal/O Max Power Requirements

	E-Series	U-Series	M-Series	S-Series	N-Series
SeaI/O-410	2.9W	1.7W	1.4W	1.6W	1.4W
SeaI/O-420	3.5W	2.3W	2.0W	2.2W	2.0W
SeaI/O-430	1.9W	0.7W	0.4W	0.6W	0.4W
SeaI/O-440	4.0W	2.8W	2.5W	2.7W	2.5W
SeaI/O-450	5.3W	4.1W	3.8W	4.0W	3.8W
SeaI/O-470	3.0W	1.8W	1.5W	1.7W	1.5W
SeaI/O-520	5.0W	3.8W	3.5W	3.7W	3.5W

TTL Power Requirements

The Seal/O-462 and Seal/O-463 use 74ABT245 octal bi-directional transceivers to provide TTL input/output capabilities and can sink 64mA and source 32mA. Each bit is pulled to +5V through a 10K ohm pull-up resistor to insure each bit is at a known state when not driven. The supply current and maximum output power are shown below.

	E-Series	U-Series	M-Series	S-Series	N-Series
SeaI/O-462	2.0W	0.8W	0.5W	0.7W	0.5W
SeaI/O-463	2.0W	0.8W	0.5W	0.7W	0.5W
Output Power	+5VDC @ 1A (5W) Maximum				

Sample Power Calculation

A typical application for SeaI/O products would use one Base module and several N-series units in a local expansion configuration. In this arrangement, with power applied to the Base module through either the DC jack or screw terminal connector and passed-through to the expansion units, attention should be given to ensure the input power to the Base module is adequate.

Example:

		Power (W)
Base Unit:	SeaI/O-430U	0.7
Expansion 1:	SeaI/O-410N	1.4
Expansion 2:	SeaI/O-440N	<u>2.5</u>
		4.6W Power Required

In this application, the Sealevel Item# **TR112** “wall wart” power supply is a good choice since it is low-cost and supplies 24VDC @ 250mA (6W).

NOTE:



A complete listing of recommended power supplies is provided in the **Accessories** section of this manual.

SeaMAX Application Suite

SeaMAX Overview

The SeaMAX Suite is a collection of software libraries, and configuration and diagnostic utilities that facilitates rapid application development. The following libraries and utilities are included in the SeaMAX Suite and are covered in this chapter:

- MaxSSD Configuration & Diagnostics utility
- Ethernet Config utility
- SeaMAX API

Sealevel digital and analog I/O modules supported by SeaMAX software are designed to work with third party applications via the SeaMAX API. To help simplify application development, the complete API documentation and code samples are automatically installed with the SeaMAX Suite and can be found in Windows by clicking Start → All Programs → Sealevel SeaMAX → Documentation.

Additional SeaMAX documentation is available online that completely details the functions of the SeaMAX API. Example code is included for several popular languages and compilers. The interactive online documentation is located on the Sealevel website at:

<http://www.sealevel.com/software/SeaMAX/>

Please contact Sealevel technical support with any questions regarding SeaMAX documentation:

Phone: (864) 843-4343

Email: support@sealevel.com.

NOTE:



This chapter covers all SeaMAX supported devices.
Not all features are applicable to all devices.

Communicating Via Modbus

Sealevel SeaI/O and SeaDAC modules are designed to integrate seamlessly into existing Modbus networks. The supported command set will vary depending on the SeaI/O model number used. Specialized diagnostic commands and other RTU specific codes are not supported. An overview of the Modbus specification for both RTU and TCP connections is covered in detail in the interactive documentation located on the Sealevel website at:

<http://www.sealevel.com/software/SeaMAX/>

The official Modbus specification can be found at:

<http://www.modbus.org>

NOTE:



SeaDAC Lite modules do not currently support Modbus commands.

SeaMAX Software Installation

Proceed with installing the **SeaMAX Software Suite** using the software CD that was included with your Sealevel I/O module. Software drivers are also available on the product webpage on the Sealevel website at www.sealevel.com.

Windows 2000/XP/Vista™ Operating Systems

Do not connect the I/O module to the host until the software is installed.

1. Start Windows.
2. Insert the Sealevel Software CD in to your CD drive.
3. If 'Auto-Start' is enabled the installation window will automatically appear. Otherwise, navigate to the root directory of your CD drive and double-click the 'autorun.exe' application to launch the installation window.
4. Select 'Install Software'.
5. Select the Part Number for your device from the listing.
6. The setup file will automatically detect the operating environment and install the proper components. Follow the information presented on the installation screens that follow.
7. A screen may appear with the declaration: "The publisher cannot be determined due to the problems below: Authenticode signature not found." Please select the 'Yes' button and proceed with the installation. This declaration simply means that the Operating System is not aware of the driver being loaded. It will not cause any harm to your system.
8. During setup, you may specify installation directories and other preferred configurations. This program also adds entries to the system registry that are necessary for specifying the operating parameters for each driver. An uninstall option is included to remove the driver and all registry/INI file entries from your system.
9. Proceed with configuring your Sealevel I/O module using the MaxSSD utility detailed on the following pages.

MaxSSD Configuration & Diagnostics Utility

The Sealevel Systems configuration utility, **MaxSSD**, is designed to simplify the installation, configuration, and diagnostics of Sealevel I/O modules. MaxSSD is a Microsoft Windows application and has been tested with Windows 2000, XP, and Windows Vista.

Host PC Configuration Tab

The first time you run the MaxSSD utility (Start → All Programs → Sealevel SeaMAX → MaxSSD) it will default to the “Host PC Configuration” tab. This tab allows the user to choose the initial communication settings for the connected I/O device. The “COM Port” dropdown box allows the selection of a serial COM port (from COM1 to COM256), Ethernet (for Ethernet SeaI/O modules), or SeaDAC Lite (USB).

USB connected SeaI/O and SeaDAC modules are installed as virtual COM ports. Using device manager, expand “Ports (COM & LPT)” by clicking on the ‘+’ next to the category, and locate the COM port for your device and use it in the dropdown box in MaxSSD.

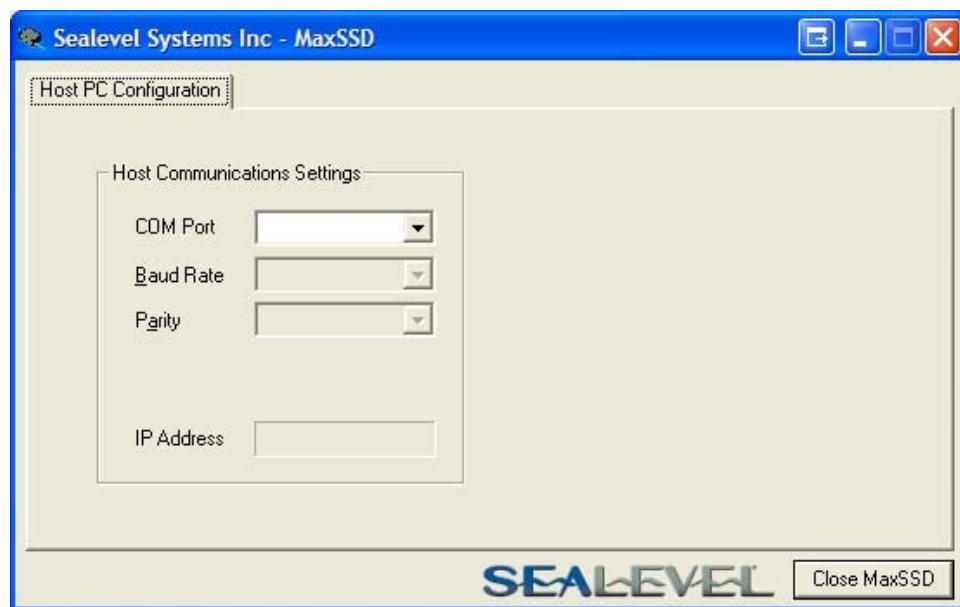

Once a COM port is selected, the baud rate and parity can be selected.

NOTE: The baud rate and parity of the PC **must** match the settings of the Sealevel I/O module to be configured. The factory default settings for all Sealevel I/O modules are 9600 baud and no parity.



Host PC Configuration Tab (cont.)

To communicate with a SeaDAC Lite module, select “SeaDAC Lite” from the “COM Port” dropdown box. MAXSSD will search for any SeaDAC Lite modules connected to a USB port and display them in a frame (as shown below). A new “Digital I/O” tab will appear. If more than one SeaDAC Lite module is connected, select the one you want to test from the list and click the “Digital I/O tab”. You can use this new tab to test the functionality of inputs and relay outputs. The “Digital I/O” tab is covered in detail on subsequent pages.

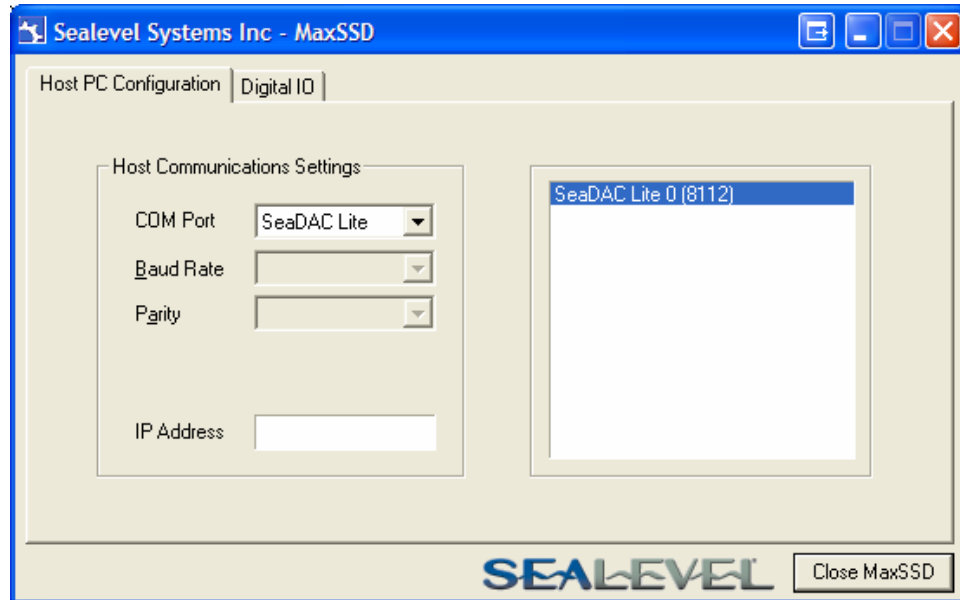

To communicate with a SeaI/O Ethernet module, select “ETHERNET” from the “COM Port” dropdown box. When Ethernet is selected, MaxSSD searches for any SeaI/O Ethernet modules on the network and displays their IP addresses in the “Available Ethernet Devices” list box (not shown). When an IP address is selected from the list box, a socket is opened to the SeaI/O module and it is ready for communication.

NOTE: If no IP address is shown when using Ethernet modules, review the previous **Hardware Configuration** section, or proceed to the **Troubleshooting** section at the end of this manual.



SeaI/O Configuration Tab

Once the host computer is configured correctly, the “SeaI/O Configuration” tab becomes available. This tab only appears for SeaI/O and SeaDAC modules and will not appear when using SeaDAC Lite modules.

Before communicating with a SeaI/O or SeaDAC module, the configuration utility must determine if there is an I/O module at that slave ID address, and if so, what type of module it is. This is the purpose of the **Get** operation.

To perform a **Get** operation, first select the slave ID to which the module is configured. SeaI/O modules are shipped at hardware setting **0** (labeled “ADDR” on the left side of the module) and slave ID **247** by default. All other slave ID addresses (from 1 to 246) are available. However, each daisy chained SeaI/O module must have a unique slave ID address - no duplicates are allowed.

SeaDAC modules are only available on slave ID **247**, and this number cannot be changed. To communicate with a different SeaDAC module, select a different COM port. Use device manager, if necessary, to locate the proper COM port.

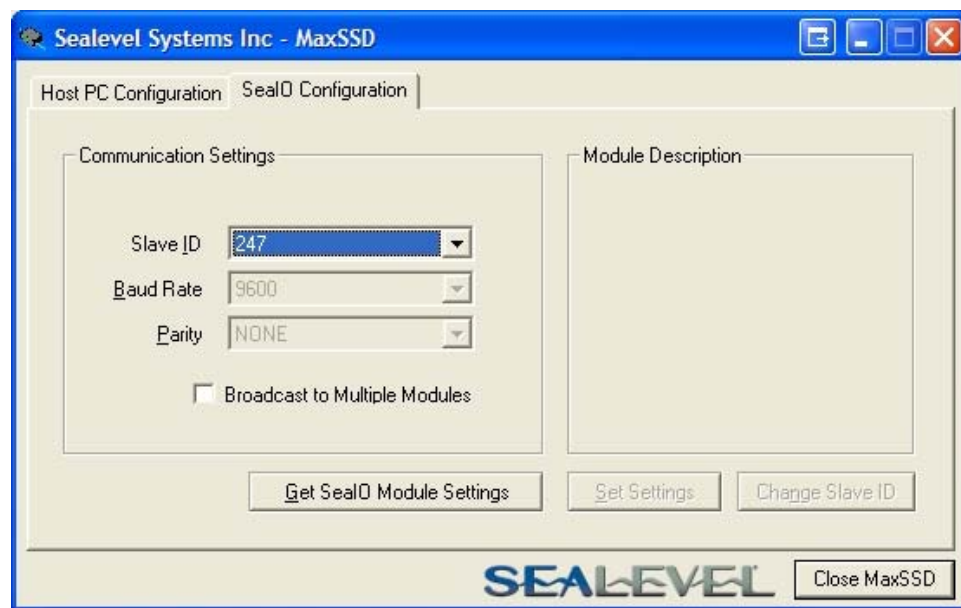

Once a slave ID is selected, click the “Get SeaIO Module Settings” button. After a short delay, the information for that I/O module should be displayed. If no information appears, verify the host settings and baud rates are correct and make changes, if necessary. For SeaDAC modules, make sure the baud rate is set to 9600bps. For SeaI/O modules, check the hardware settings (on the left side of the module) and try again.

Seal/O Configuration Tab (cont.)

After the **Get** command is executed, the “Module Description” frame will display the model type, description, interface, and I/O type. In the example shown, the module found at slave ID 247 is a SeaI/O-410 module with an Ethernet (Modbus TCP) interface. The “Set Settings” and “Change Slave ID” buttons will also be enabled for this module.

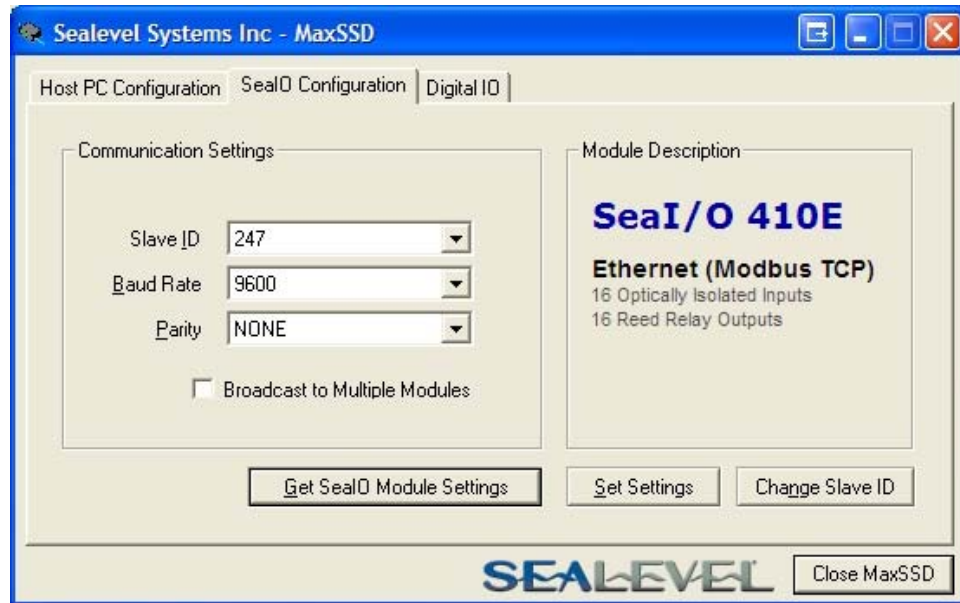

After a successful **Get** operation, additional tabs may be displayed in MaxSSD, depending on the found device model. These tabs display device I/O and allow easy configuration for all SeaMAX supported devices.

Seal/O Configuration Tab (cont.)

The “Broadcast to Multiple Modules” checkbox, along with the “Set Settings” button can be used to change the baud rate and parity on multiple Seal/O modules at once. This function only works with Seal/O modules connected together via the pass-through connectors. This function is disabled with SeaDAC and SeaDAC Lite modules since these devices do not have pass-through connectors.

MaxSSD broadcasts a set data rate and set parity command to all devices on the RS-485 bus, but only those modules listening at the current baud rate will be able to receive and respond. For example, if you have five Seal/O modules chained together and two are set to 9600 bps and no parity and three are set to 115.2k bps and the PC is set to 9600 bps, only the two modules set to 9600 bps will receive the broadcast set data rate and parity message.

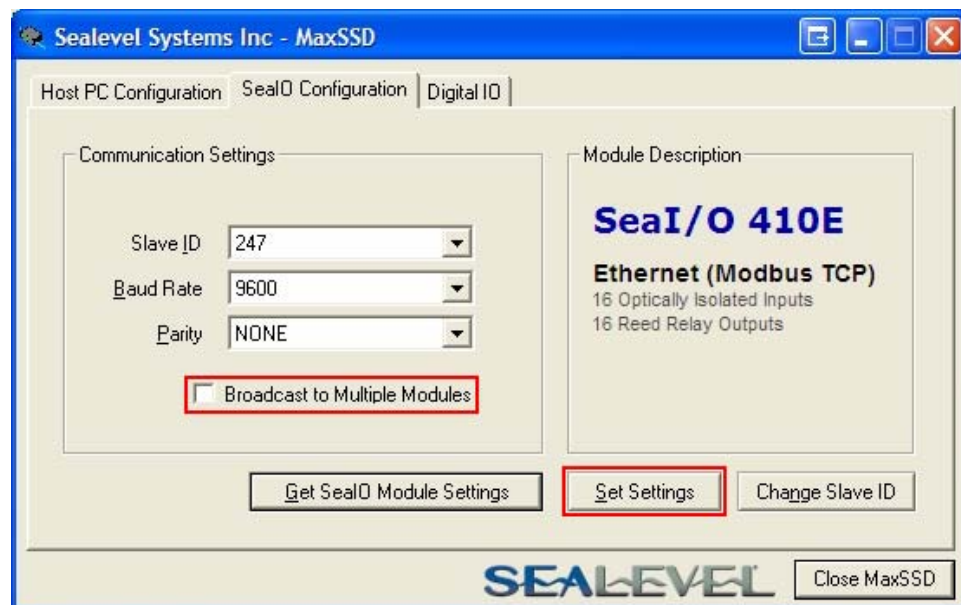

NOTE: **Important note regarding Seal/O Ethernet (E-series) modules**

 The broadcast feature sets the Ethernet Seal/O (E-series) module’s TCP/IP to RS-485 translation data rate independently of the Seal/O module itself. Therefore, if you have an Ethernet Seal/O module and you set the data rate to 115.2K bps via a MaxSSD broadcast command, both the RS-485 port and the Ethernet port will respond thereafter to 115.2K bps, as expected. However, if you reset the Seal/O module by rotating the rotary switch clockwise one complete revolution, the RS-485 port will reset to 9600 bps and no parity, but the Ethernet port will remain unaffected. To restore communications, broadcast another set data rate and parity command (9600 and no parity) via MaxSSD.

Digital I/O Tab

The “Digital IO” tab of MaxSSD is displayed when using Sealevel I/O devices featuring discrete inputs and outputs. It displays the device’s current input and/or output status in an intuitive and usable manner.

When displaying SeaI/O or SeaDAC modules (excluding SeaDAC Lite), the “Digital IO” tab displays inputs and outputs in groupings (or banks) of eight. Therefore, a Sealevel I/O device with 16 inputs and 8 outputs would show two banks of inputs and one bank of outputs.

When banks of inputs are displayed, the status LEDs update on each of the banks automatically. This allows you to actively monitor external signals.

With a bank of outputs, the output coils can be set using the buttons below each output LED. As each coil is set, the I/O module is read. The corresponding status LED in the “Digital IO” window indicates the state of the coil. In the example below, a SeaI/O module with 16 Reed relays is shown.

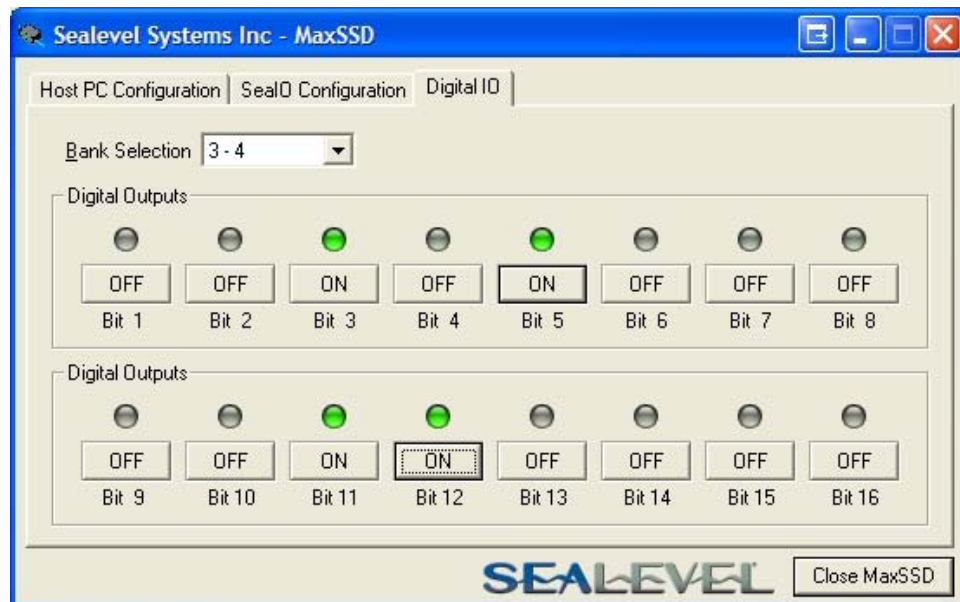

Digital I/O Tab (cont.)

When displaying SeaDAC Lite modules, the “Digital IO” tab displays inputs and outputs in groupings (or banks) of four. Therefore, a SeaDAC Lite module with four inputs and four outputs would show only one bank of inputs and one bank of outputs.

When banks of inputs are displayed, the status LEDs update on each of the banks automatically. This allows you to actively monitor external signals.

With a bank of outputs, the output coils can be set using the buttons below each output LED. As each coil is set, the SeaDAC Lite module is read. The corresponding status LED in the “Digital IO” window indicates the state of the coil. In the example below, a SeaDAC Lite module with four inputs and four Form C relays is shown, with the state of the relays showing either normally-open (NO) or normally-closed (NC).

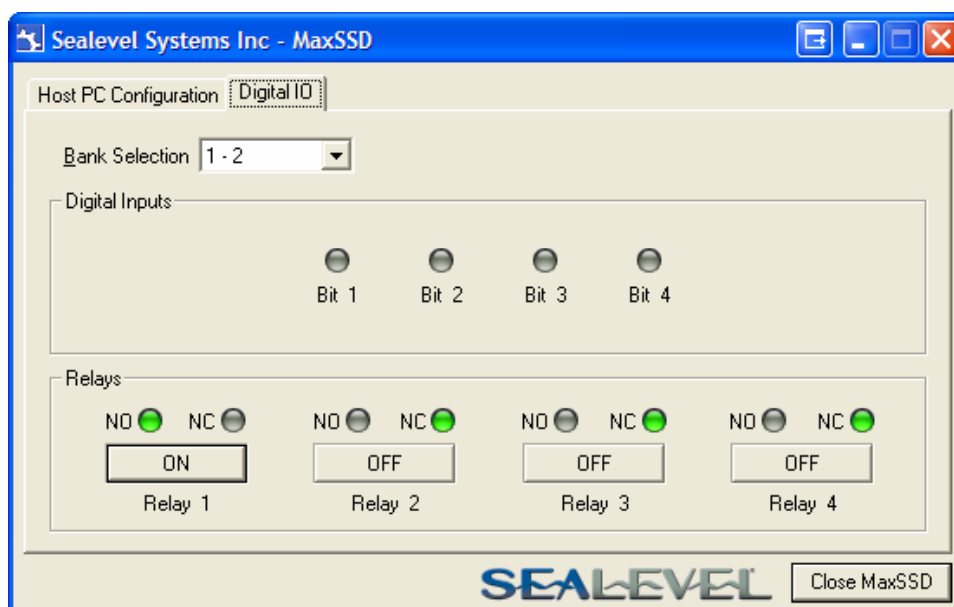

NOTE: The “SeaIO Configuration” tab does not appear in MaxSSD when using SeaDAC Lite modules since they have no configurable communication settings.



Programmable I/O Tab

The “Programmable IO” tab of MaxSSD is displayed when using Sealevel I/O devices featuring programmable inputs or outputs. This tab allows for bank configuration, input/output configuration, as well as bit-level presets.

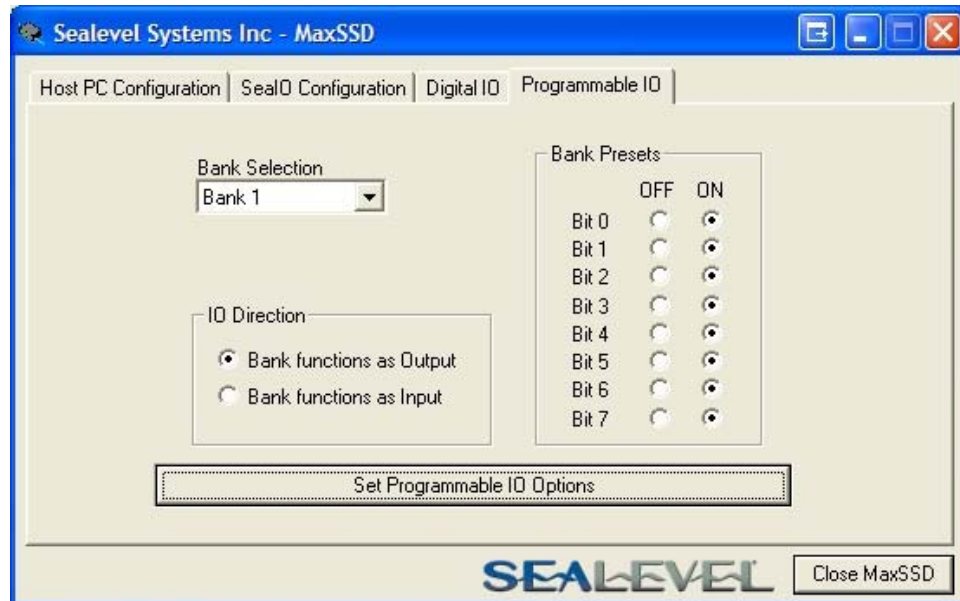

Each bank of programmable I/O can be set as either an 8-bit group of inputs or outputs. By selecting “Bank 1” from the drop-box, clicking the “Bank functions as Input” radio button, and then clicking the “Set Programmable IO Options” button, the first 8 PIO bits on the device will now function as inputs. For ease of configuration, an “All Banks of IO” option is available to configure all of the I/O at one time.

Inputs have no preset mode; therefore, the preset options are disabled for any bank of inputs. Outputs; however, have bit-addressable presets. These presets are used whenever the device is powered up or the bank direction changes from input to output.

NOTE: The output presets, will not lock the outputs into a specified on or off state. They only set the state of the outputs on a power on or bank direction change.



A/D Inputs Tab

The “A/D Inputs” tab displays the current state of the analog-to-digital channels for Sealevel I/O devices that feature A/D inputs. Settings are provided for both device wide and per-channel configuration.

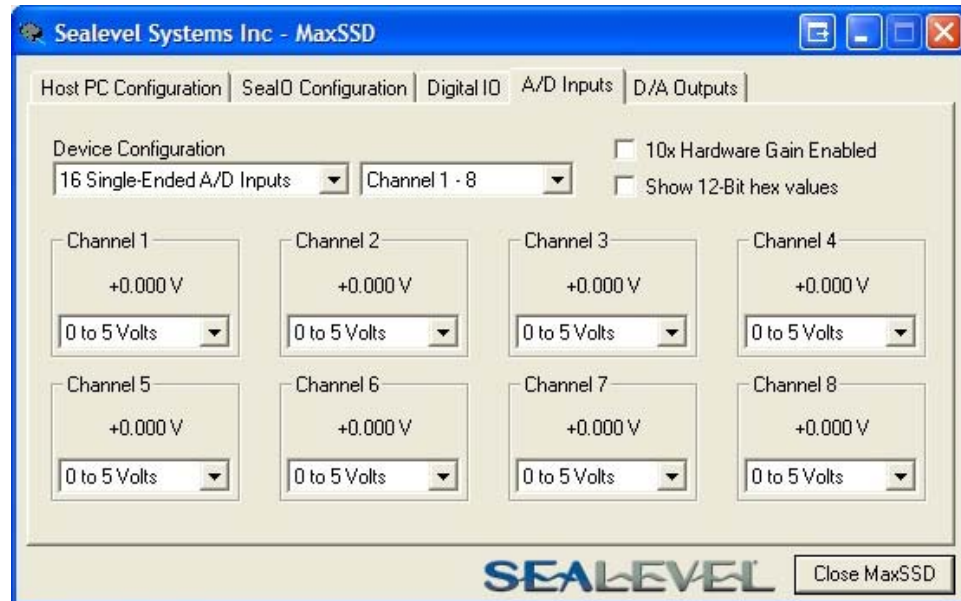

The “Device Configuration” selection drop-box adjusts the arrangement and function of the A/D input channels. Input channels are displayed as banks (groups of eight). Each channel is range configurable via the voltage range dropdown list. Both the channel voltage range and device-wide configuration are set on a dropdown list. There is no need to save your settings – they are automatically saved to the device as you select the various configuration options.

“10x Hardware Gain Enabled” checkbox – Indicates whether or not the onboard hardware gain jumper is currently set. This option is **not** user configurable – it only reflects the status of the onboard hardware jumper settings. Set the hardware jumper to enable this functionality, which allows smaller voltages to be measured more accurately (e.g., a 0-1V input signal can be measured more accurately by enabling the 10x hardware gain jumper and setting the Seal/O-470 A/D input channel for 0-10V range).

“Show 12-Bit Hex Values” checkbox – Displays the values returned by the A/D converter as a hexadecimal value without converting the values to engineering units (i.e., Amps or Volts)

D/A Outputs Tab

The “D/A Outputs” tab is useful for manually setting the digital to analog output voltages on applicable Sealevel I/O devices with D/A channels. A preliminary diagnostics utility (see following page) has been provided to verify proper hardware functionality.

The D/A outputs of the SeaI/O-470 and SeaDAC 8227 are factory set for 0-10V. To configure the D/A outputs for 0-5V, you will need to open the enclosure and set the correct jumpers. Refer to the **Hardware Configuration** section of this manual for instructions on opening the enclosure and accessing the correct jumpers.

To adjust a particular channel’s output voltage, drag the slider until the desired voltage is displayed in the window on the right side. Also, you may type the desired voltage directly into the voltage display and then confirm your entry by pressing the ‘Enter’ key on your keyboard.

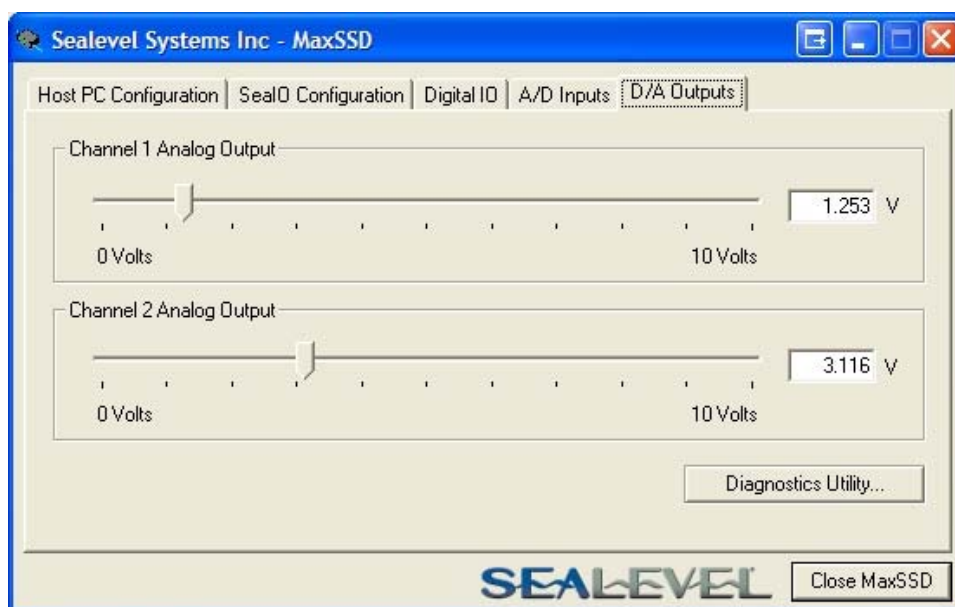

NOTE: The output voltage will not change until the ‘Enter’ key is pressed or you have clicked on the window anywhere outside of the text entry field.



A/D & D/A Diagnostics

To check basic functionality of both the A/D and D/A converters, press the “Diagnostics Utility” button on the “D/A Outputs” tab (shown on the previous page) and then press the “Start” button, as shown below. Any errors will be shown in the “Results” pane. If any errors occur, please contact technical support for further help.

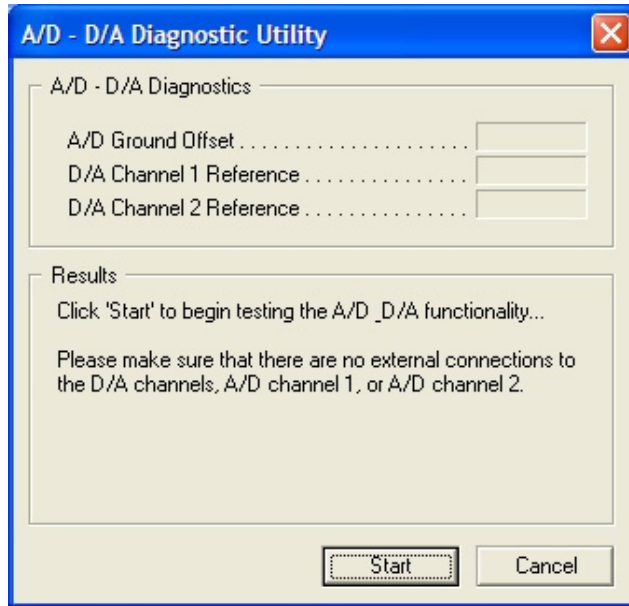

Converting A/D & D/A Values

To properly use the values returned from the SeaI/O-470 and SeaDAC 8227 module’s A/D channels, the application program must convert the returned values to engineering units (voltage). Likewise, the application program must output the correct value to the I/O module’s D/A outputs to generate the desired voltage.

The conversion formulas will vary depending on how the I/O module is configured. The formulas and their uses are covered in detail in the interactive documentation located on the Sealevel website at:

<http://www.sealevel.com/software/SeaMAX/>

Troubleshooting SeaMAX

Following these simple steps can eliminate most common problems.

1. Read this manual thoroughly before attempting to install the device in your system.
2. Uninstall any previous versions of the SeaMAX software before installing any new versions.
3. **Install SeaMAX software first, before connecting any Sealevel I/O devices.** Installing the software places the necessary files in the proper locations on your system. After installing the software, proceed with adding the hardware.
4. When installing Seal/O modules, connect them one at a time. The “base” module must be properly configured and communicating successfully with the host before you can add additional expansion modules. Verify each expansion module can communicate before connecting additional expansion modules.
5. Confirm that all screw terminal connections are correct and secure and that the correct cables are being used, including network cables (crossover vs. patch cables).
6. You can use standard network patch cables (straight-through cables) to connect Seal/O modules together via the pass-through connectors on the left side of the module. Crossover cables should never be used to connect two or more Seal/O modules together. Crossover cables should **only** be used to connect an Ethernet Seal/O module to a host without going through an Ethernet hub or switch.
7. On Seal/O modules, verify that the device address (slave ID) is properly set. Refer to the **Hardware Configuration** section of this manual for instructions on setting the device slave ID.
8. Use the MaxSSD utility, included on the software CD, to verify proper installation. MaxSSD is designed to simplify the installation, configuration, and diagnostics of Sealevel Seal/O modules.
9. If the Seal/O modules only sometimes respond to a **Get** operation or return invalid data, you may have termination improperly set. Refer to the **Hardware Configuration** section of this manual for instructions on properly setting line termination and pull-up/pull-down resistors.
10. Refer to the **Troubleshooting Ethernet Modules** section on the following page for additional steps regarding Ethernet (E-series) Seal/O modules.
11. If these steps do not solve your problem, please contact Sealevel Technical Support. Our technical support is free and available from 8:00AM-5PM Eastern Time, Monday through Friday. You can contact Technical Support via:
Phone: (864) 843-4343
Email: support@sealevel.com

Troubleshooting Ethernet (E-series) Sea/O Modules

Problem: The Sea/O module starts up with a strange IP address (i.e., 169.254.x.x)

All Ethernet Sea/O (E-series) modules are shipped with DHCP enabled. If no DHCP server is available or the DHCP server cannot be reached, the Ethernet Sea/O module will default to a random IP address in the range 169.254.0.1 to 169.254.255.254. Change the PC's network settings to place both the Sea/O module and PC on the same subnet. Adjust the Sea/O module's IP address and Netmask using the **Ethernet Config** utility (Start → All Programs → Sealevel SeaMAX → Ethernet Config) installed with SeaMAX. Then restore the PC's network settings.

Problem: The Sea/O module is visible in Ethernet Config, but the network settings cannot be changed

The Sea/O module is most likely on a different subnet than the PC. The PC's IP address and Netmask must be altered to place both the Sea/O module and the PC within the same subnet. Contact your network administrator for assistance.

Problem: The Sea/O module doesn't show up in Ethernet Config

The Ethernet Sea/O modules are discovered via a UDP broadcast. Verify that any firewall software, such as Windows Firewall, ZoneAlarm, etc., or router settings that would hinder UDP transmissions are disabled.

It is also possible that the Sea/O module may not be discovered if the PC and module are on separate subnets. This may occur if the module's IP address is configured outside the range of the PC's subnet. It can also occur during a failed DHCP discovery. In either case, the "Recover Module" button in Ethernet Config utility may be used to recover the device. Refer to the **Hardware Configuration** section of this manual for more information.

Problem: The rotary switch (ADDR) was used to reset an Ethernet Sea/O module, but it no longer responds to a 'Get' operation.

If you reset the Sea/O module by rotating the rotary switch clockwise one full revolution, the RS-485 port will reset to 9600 bps and no parity, but the Ethernet port will remain unaffected.

The broadcast feature in MaxSSD sets the Ethernet Sea/O (E-series) module's TCP/IP to RS-485 translation data rate independently of the Sea/O module itself. Therefore, if you have an Ethernet Sea/O module and you set the data rate to 115.2K bps via a MaxSSD broadcast command, both the RS-485 port and the Ethernet port will respond thereafter to 115.2K bps, as expected. Using the rotary switch will reset the RS-485 port, but the Ethernet port will still try to communicate at 115.2k bps. To restore communications, broadcast a set data rate and parity command (9600 and no parity) via MaxSSD.

Hardware Configuration

Device Address Configuration

Before configuring SeaI/O modules using MaxSSD, you must first select a device addressing method. Next, you must properly set termination and pull-up/pull-down resistors. Finally, you must configure the SeaI/O modules one at a time before MaxSSD and any subsequent applications (using the SeaMAX API) will be able to successfully communicate.

Setting Device Address (Slave ID)

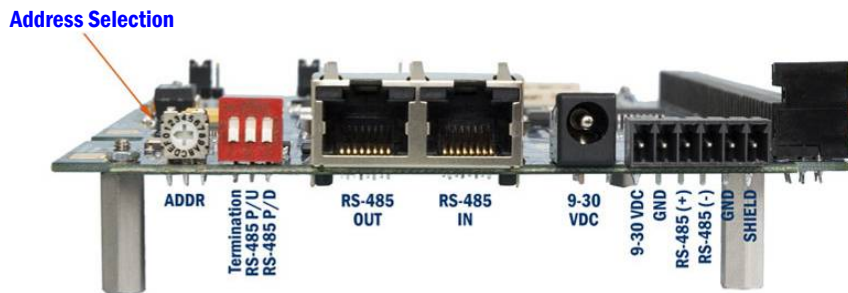

SeaI/O modules have a rotary switch located on the left side of the board that is used to set the device address (slave ID). The default position for all SeaI/O modules is position “0” (zero). Each SeaI/O module must be set to a unique slave ID in order to properly communicate with the host device, which can be a computer or Modbus device. The slave ID can be set by hardware using the rotary switch, which is recommended for most users. The slave ID can also be set in software by leaving the rotary switch at position “0” and using MaxSSD to set the slave ID. The rotary switch has three functions:

- **Set Address (slave ID) via Hardware** – If the rotary switch is set to a position between “1” and “15” (F), the SeaI/O module will always respond to commands issued at that slave ID. This is useful when there are fewer than 16 SeaI/O modules in a chain and the slave ID is not required to change. This method is recommended for most users.
- **Set Address (slave ID) via Software** – If the rotary switch is left in the “0” (zero) position, the SeaI/O module uses a default slave ID of 247 for communications. By using MaxSSD (or the SeaMAX libraries), it is possible to set the slave ID to a software address between 1 and 247. This is useful when there are more than 16 SeaI/O modules in a chain, or when the slave ID of a module needs to be frequently changed.
- **Hardware Reset** – If you have an existing SeaI/O module set to an unknown slave ID or baud rate, you may wish to reset the device. If the rotary switch is rotated clockwise one full revolution, the SeaI/O module will be reset to factory defaults (slave ID 247, 9600 bps, and no parity).

NOTE: A Hardware Reset will not reset the communication rate of an Ethernet (E-series) module. Rotate the rotary switch clockwise one full revolution, and then use the MaxSSD utility to broadcast a set baud rate command to 9600 bps and no parity.



Setting Termination & Pull-Up/Pull-Down Resistors

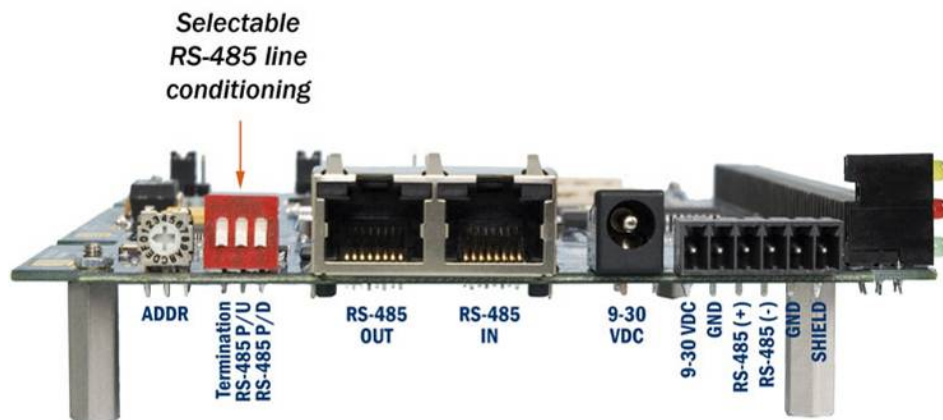

A “stack” or “chain” of SeaI/O modules, connected via the pass-through connectors or screw terminals on the left side of the board, communicates via an RS-485 bus, which must be properly terminated to work correctly. A set of three dipswitches is located on the left side of board, next to the rotary switch. These switches control line termination and the RS-485 pull-up and pull-down resistors.

The pull-up and pull-down resistors ensure that the input ports are at a known state when not being driven by the RS-485 line. In most cases, all three of the dipswitches on each SeaI/O module should be in the down position, except the two end modules. The first and last SeaI/O modules in the chain should have all three dipswitches in the up (enabled) position.

NOTE: Make sure that only the first and last SeaI/O modules have line termination enabled (up position). Improper termination settings can result in invalid data or communication failures.



Configuring the “Base” Seal/O Module

Once the **SeaMAX Software Suite** has been installed successfully and you have decided which address (slave ID) method you intend to use, start by connecting the E-, U-, M-, or S-series module to your computer. This module will be referred to as the “base” module.

If you are chaining multiple Seal/O modules together, only one Seal/O module in the chain can be the “base”. All other Seal/O modules connected to the “base” module are referred to as expansion modules. Multiple “base” modules can be directly connected to a host computer, but expansion modules must be connected (daisy chained) to a “base” module.

NOTE:  If you are configuring an Ethernet Seal/O (E-series) module, skip ahead to the **Configuring an Ethernet Module** section for additional information on installing an Ethernet module.

For all other Seal/O modules (U-series, S-series, or M-series), locate the COM port by expanding the ‘Ports’ list in Windows Device Manager.

Start MaxSSD (Start → All Programs → Sealevel SeaMAX → MaxSSD) and choose the correct port (IP address or COM port) to communicate with the “base” module. Ensure a successful **Get** operation (refer to the **MaxSSD** section on the following pages for more information).

Set the slave ID of the “base” module using the rotary switch or software selection method discussed in the **Setting Device Address** section on the previous pages. This guarantees that any expansion modules connected next will not conflict with the “base” module. Perform another **Get** operation to verify that you can communicate with the “base” module at the new slave ID.

NOTE:  Configure the Seal/O modules one at a time. Set the address to a hardware slave ID other than “0” or a software slave ID other than 247, which avoids device conflicts during setup.

After the “base” module is successfully communicating via MaxSSD, you can proceed with adding Seal/O expansion modules (N-series), as required.

NOTE:  If the “base” module doesn’t respond as expected, turn the rotary switch, located on the left side of the board, clockwise one full revolution to reset. Configure the PC to communicate at 9600 bps and no parity and then try again.

Configuring N-Series Expansion Modules

Once you have successfully connected and communicated with a “base” module, you can begin adding expansion modules (N-series). Connect a single expansion module to the “base” module via the RJ45 pass-through connectors or screw terminals on the left side of the board. Expansion modules include a convenient 5” interconnect cable (item# CA239) to simplify daisy-chaining SeaI/O modules together. Alternately, you can use standard network patch cables to chain expansion modules to a “base” module.

NOTE: The RJ45 pass-through connectors are **NOT** Ethernet connectors. **Do not** connect the ports to Ethernet enabled devices else damage to Ethernet devices **WILL** result.



Ensure a successful **Get** operation (refer to the MaxSSD section on the following pages for more information). Set the slave ID of the expansion module using the rotary switch or software selection method discussed in the Setting Device Address section on the preceding pages. Perform another **Get** operation to verify that you can communicate with the expansion module at the new slave ID.

Continue adding expansion modules (N-series), one at a time, until all modules have been successfully daisy-chained together and respond to a **Get** operation in MaxSSD. Once all SeaI/O modules are configured and communicating successfully, they are ready to communicate with your application.

Configuring an Ethernet Module (E-Series)

NOTE: This section applies only to Ethernet SeaI/O (E-series) modules. For all other SeaI/O modules, refer to the **Configuring a “Base” SeaI/O Module** and **Configuring Expansion Modules** sections on the previous pages.



Verify that SeaMAX has been installed successfully and that an Ethernet SeaI/O module is connected to your computer. This module will become the “base” module.

All Ethernet SeaI/O (E-series) modules are shipped with DHCP enabled. When you first connect an Ethernet SeaI/O module to the network, the status LEDs on the front of the module will blink while it searches for a DHCP server. Once it receives an IP address, the status LEDs will remain on.

If no DHCP server is available, the Ethernet SeaI/O module will default to a random IP address in the range 169.254.x.x. To discover the Ethernet SeaI/O module’s IP address, start the **Ethernet Config** utility (Start → All Programs → Sealevel SeaMAX → Ethernet Config) installed with SeaMAX.

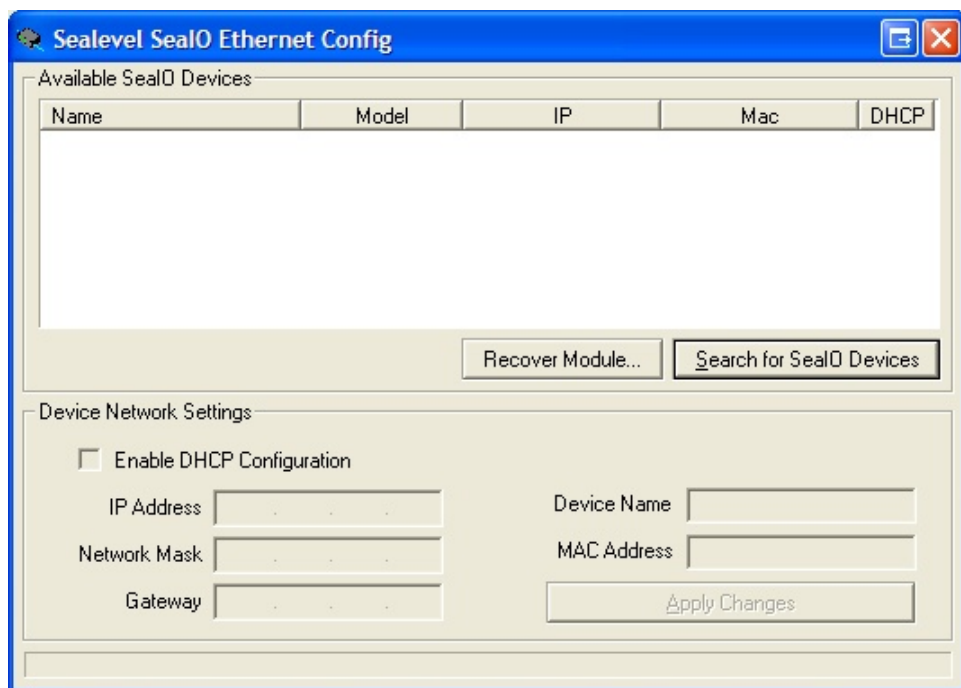

Click on the “Search for SeaI/O Devices” button and the ‘Available SeaI/O Devices’ pane should refresh with any Ethernet SeaI/O modules that are found on the network. Select one of the modules in the list by clicking on it. You can update the settings in the Device Network Settings pane and then confirm these changes by clicking the “Apply Changes” button. The module list should refresh, indicating that your changes were successful.

Configuring an Ethernet Module (Continued)

NOTE: If the module does not change or respond, the PC and the module may be on different subnets. Proceed to the Recover Module section on the following page.



Start MaxSSD (Start → All Programs → Sealevel SeaMAX → MaxSSD) and choose the correct IP address to communicate with the “base” Ethernet SeaI/O module. Ensure a successful **Get** operation (refer to the **MaxSSD** section on the following pages for more information).

Set the slave ID of the “base” Ethernet SeaI/O module using the rotary switch or software selection method discussed in the **Setting Device Address** section on the previous pages. This guarantees that any expansion modules connected next will not conflict with the “base” module. Perform another **Get** operation to verify that you can communicate with the “base” Ethernet SeaI/O module at the new slave ID.

NOTE: Configure the SeaI/O modules one at a time. Set the address to a hardware slave ID other than “0” or a software slave ID other than 247, which avoids device conflicts during setup.



After the “base” Ethernet SeaI/O module is successfully communicating via MaxSSD, you can proceed with adding SeaI/O expansion modules (N-series). Refer to the **Configuring Expansion Modules** section on the previous pages.

Resetting an Ethernet Seal/O Module

An Ethernet Seal/O module may become no longer visible in the module list in the **Ethernet Config** utility if the Ethernet Seal/O module has been configured to use a different subnet than the host computer.

In other cases, the Ethernet Seal/O module doesn't appear in the module list due to a DHCP discovery failure. In either case, clicking on the "Recover Module" button (see image on previous page) in the **Ethernet Config** utility will bring up the "Module Reset" window shown below.

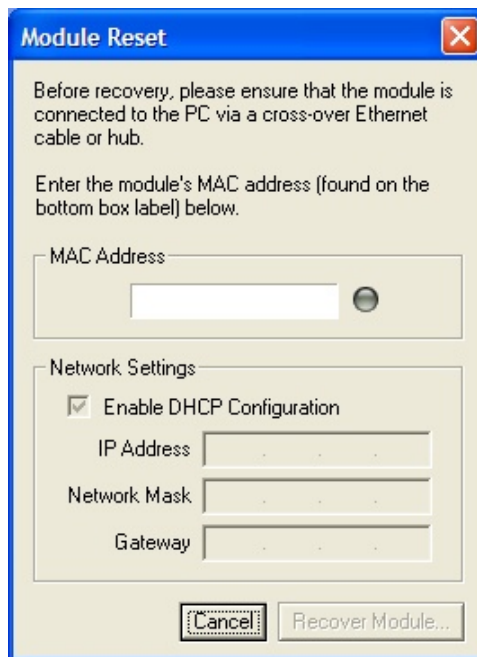

Before recovery begins, make certain that the PC and Ethernet Seal/O module are on the same network segment – they should be connected with an Ethernet crossover cable, through a hub, or through a non-routing switch. Ethernet Seal/O modules are shipped with both an Ethernet patch cable (blue) and an Ethernet crossover cable (yellow).

Enter the MAC address found on the label on the Sea/O board. A MAC address is made up of six pairs of hex digits separated by dashes (i.e., xx-xx-xx-xx-xx-xx). While entering the MAC address, the indicator to the right of the field will turn red if the MAC address entered is invalid. Once a MAC address is successfully entered, the indicator light will turn green and the "Network Settings" options will be enabled.

Contact your network administrator if you are unsure of the proper network settings to choose. If a DHCP server is available, select the "Enable DHCP Configuration" checkbox. Otherwise, complete the network settings and click the "Recover Module" button to complete the configuration changes.

Proceed with configuring expansion modules, explained in the previous section.

Seal/O-470 Jumper and Dipswitch Settings

The Seal/O-470 module ships factory configured with the D/A outputs set for 0-10V and current loop mode on the A/D inputs disabled. If you need to enable current loop mode or set the D/A outputs to 0-5V, you will need to configure the jumpers.

Seal/O-470 Jumper Locations

This detail image of the right side of the Seal/O-470 circuit board shows the locations of the user configurable jumpers and dipswitches. Refer to the following pages for instructions on properly configuring the jumpers and switches. The colored boxes are shown here for clarity and are not visible on the actual circuit board.

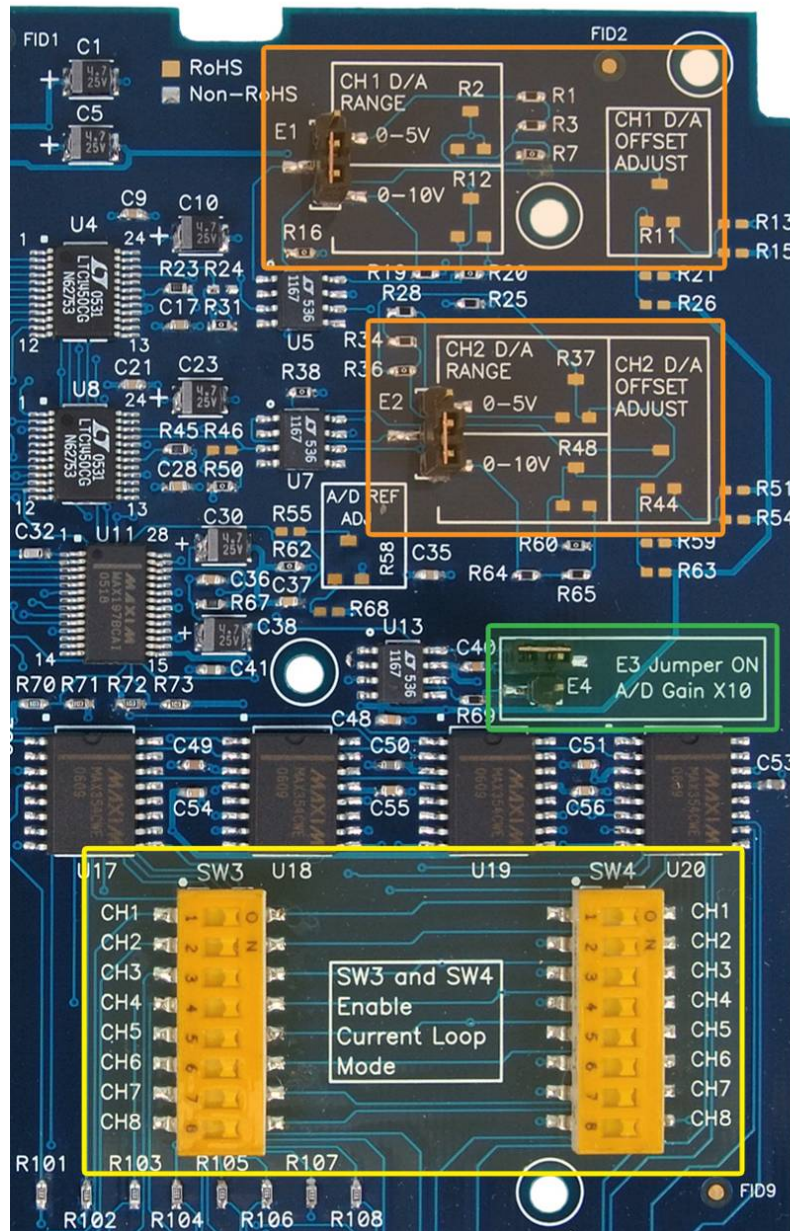

D/A Settings

The (E1) and (E2) jumpers (shown in the orange boxes on the previous page) configure the D/A outputs for 0-5V or 0-10V. Both channels can be configured independently. The D/A outputs do not support negative voltages. You must also set the correct output voltage in your application or MaxSSD. Refer to the **SeaMAX Application Suite** section of this manual for help configuring software to work with the Sea/O-470.

A/D 10X Gain

The A/D 10X gain (E3) jumper (shown in the green box on the previous page) is disabled at the factory. Position the hardware jumper on both pins to enable this functionality, which allows smaller voltages to be measured more accurately (e.g., a 0-1V input signal can be measured more accurately by enabling the 10x hardware gain jumper and setting the Sea/O-470 A/D input channel for 0-10V range). You can also set the A/D input channel for 0-5V to sense voltages smaller than 0.5V.

When the jumper is enabled, the “10X Hardware Gain” checkbox will also be enabled on the A/D Inputs tab in MaxSSD. Refer to the **SeaMAX Application Suite** section of this manual for information on using MaxSSD.

A/D and Current Loop Dipswitches

The (SW3) and (SW4) dipswitches (shown in the yellow box on the previous page) configure the A/D inputs for current loop mode and are disabled at the factory. Since current loop mode is differential, the corresponding dipswitch on both (SW3) and (SW4) should be properly set (e.g., ‘CH1’ on both dipswitches needs to be set to ‘ON’ to enable current loop mode).

SW3 – enables the current-loop sensing resistor

SW4 – ties the other half of connection to ground

Wiring Options

Seal/O Pass-Through Connector

All Seal/O modules include two RS-485 pass-through connectors on the left side of the board that are internally connected to the same pins on the screw terminals. This offers two convenient options for adding additional expansion modules.

For connecting several Seal/O modules together in a “stack”, all N-series expansion modules ship with a 5” RJ45 RS-485 interconnect cable (item# CA239). The interconnect cable can be used to connect Seal/O modules together via the RJ45 pass-through connectors, providing an easy method to cascade RS-485 signals and power from one module to the next.

For expansion modules that are less than ten feet from a base unit, a standard RJ45 CAT5 patch cable may be used. For Seal/O modules greater than ten feet apart, use twisted-pair cable connecting the data lines to the screw terminals instead. **If RJ45 connectors are preferred, be sure to connect only the data lines (pins 4 & 5).**

NOTE: When using standard CAT5 patch cables to connect modules less than ten feet apart, ensure the cables are wired “straight-through.”  **DO NOT** connect network crossover cables to the pass-through connectors, else damage to equipment may result.

NOTE: Modules greater than ten feet apart must have separate power supplies. Refer to the **Power Options** section of this manual for recommendations. 

**RJ45 (RS-485 IN/OUT)
Pass-Thru Connector**

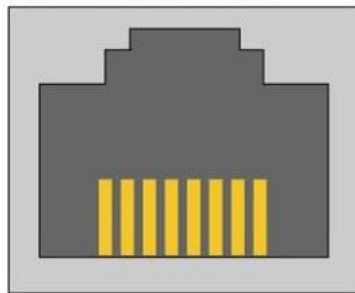

Pin Out

Pin #	Signal
1	9-30 VDC Source
2	9-30 VDC Source
3	Not connected
4	485+
5	485-
6	Common (GND)
7	Common (GND)
8	Common (GND)

I/O Wiring – Seal/O–410, 420, 430, 440, and 450 Modules

Optically isolated inputs are arranged such that each group of four shares a single common. The four I/O points and shared common are connected via a five-position removable screw terminal. Input voltage range is 5-30VDC. Like the inputs, each group of four Reed relays also shares a single common and connects via a five-position removable screw terminal. Form C Relay outputs are arranged such that each group of two relays shares a common. The NC and NO contacts of each relay along with the common are brought out via a five-position removable screw terminal.

Optically Isolated Inputs

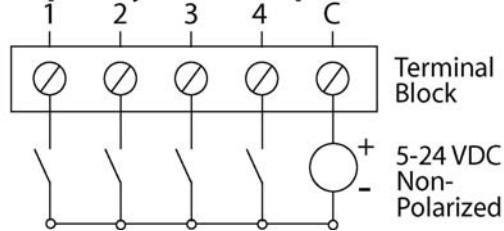

Reed Relay Outputs

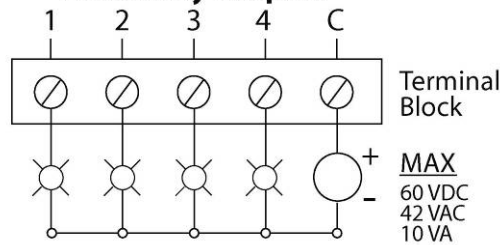

Form C Relay Output

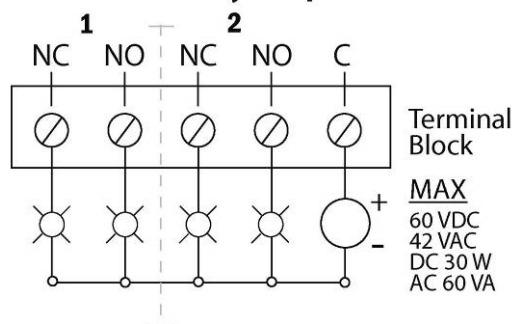

I/O Wiring – Seal/O–462 and 463 Modules

Seal/O–462 DB–78F Connectors

The Seal/O-462's 96 digital I/O channels are brought out to two DB-78 Female connectors on the front of the board (pinout shown below). Each connector provides 48 bits of digital I/O divided into six eight-bit ports. Each port may be individually configured via software command as an input or an output.

Bits 1-48						
Bits	A1	B1	C1	A2	B2	C2
D0	75	38	18	10	30	2
D1	76	37	17	9	29	1
D2	77	36	16	8	28	22
D3	78	35	15	7	27	21
D4	59	34	14	6	26	40
D5	39	33	13	5	25	60
D6	20	32	12	4	24	61
D7	19	31	11	3	23	62

Bits 49-96						
Bits	A3	B3	C3	A4	B4	C4
D0	75	38	18	10	30	2
D1	76	37	17	9	29	1
D2	77	36	16	8	28	22
D3	78	35	15	7	27	21
D4	59	34	14	6	26	40
D5	39	33	13	5	25	60
D6	20	32	12	4	24	61
D7	19	31	11	3	23	62

Power & Commons	
+5V	63, 74
Commons	41 – 58, 64 – 73

Seal/O-462 Optional Cable (Item# CA237) Pinout

For easy connection to industry-standard solid-state relay racks, Sealevel manufactures a 6' cable, Item# CA237, that terminates the DB-78 to two industry standard 50-pin header connectors. Two cables and a Seal/O unit can be ordered together as a kit using Item# 462x-KT. The pinout for the two 50-pin headers is shown below.

Port 1 (Bits 1-48)

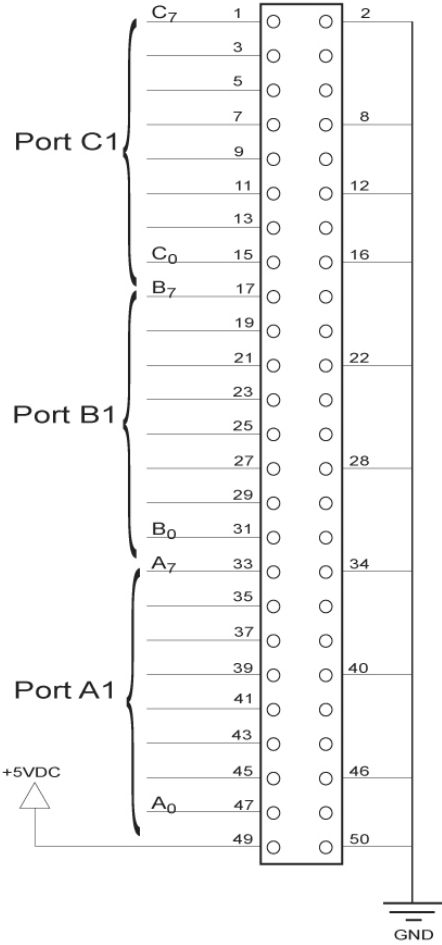

Port 2 (Bits 49-96)

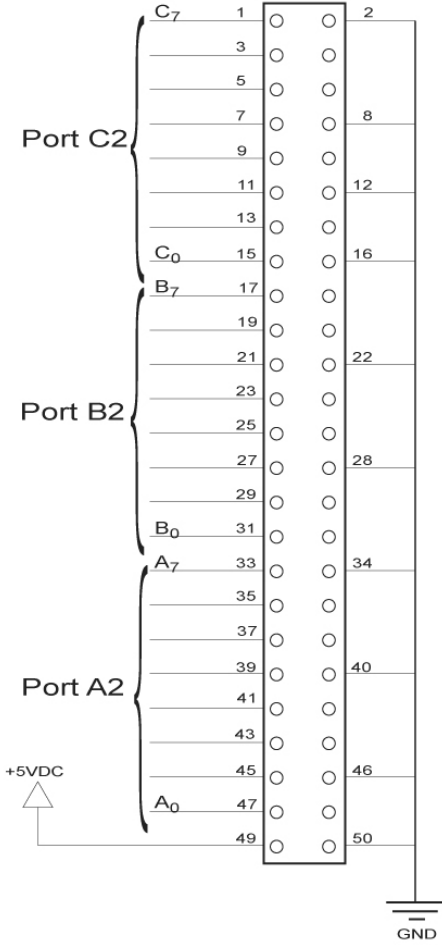

Seal/O-463 50-Pin Header Connectors

The Seal/O-463's 96 digital I/O channels are accessed via four industry-standard 50-pin header connectors. Each header provides 24 bits of digital I/O divided into three eight-bit ports. Each port may be individually configured via software command as an input or an output.

The Seal/O-463's four header connectors are labeled: P2, P3, P4, and P5. The connector designators are silk-screened onto the PCB for easy identification. Each of the four 50-pin connectors has the following pinout, which is compatible with a wide variety of industry-standard solid-state relay racks:

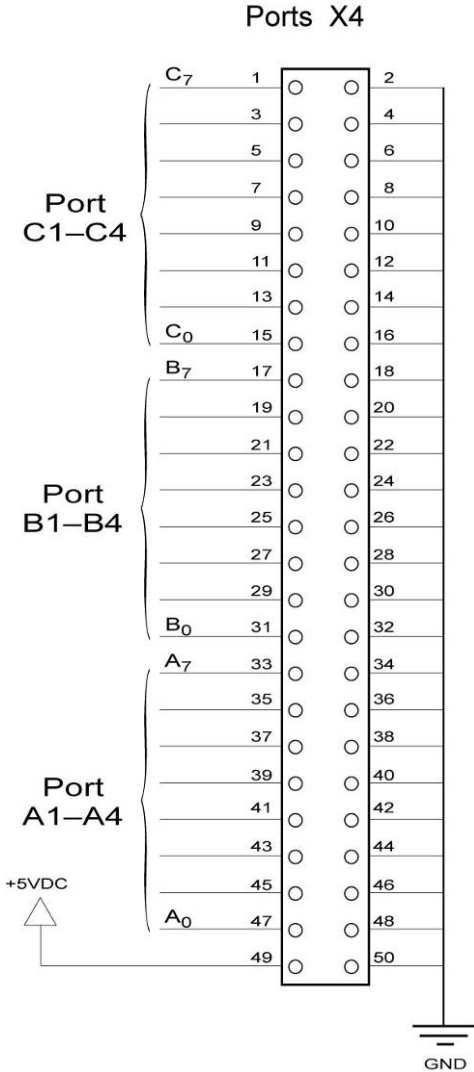

I/O Wiring – Seal/O-470 Modules

A/D Wiring Connections

The Seal/O-470 supports single-ended, differential, and current loop A/D inputs. Single-ended and differential modes can be configured in software. Current loop mode requires configuring dipswitches on the board. Refer to the **Hardware Configuration** section of this manual for instructions on configuring the current loop dipswitches.

The Seal/O-470 can be configured for up to sixteen 12-bit single-ended A/D inputs. Each input is referenced to a common ground. The user selectable voltage ranges are 0-5V, 0-10V, +/-5V, and +/-10V.

Sixteen 12-Bit Single-Ended A/D Inputs

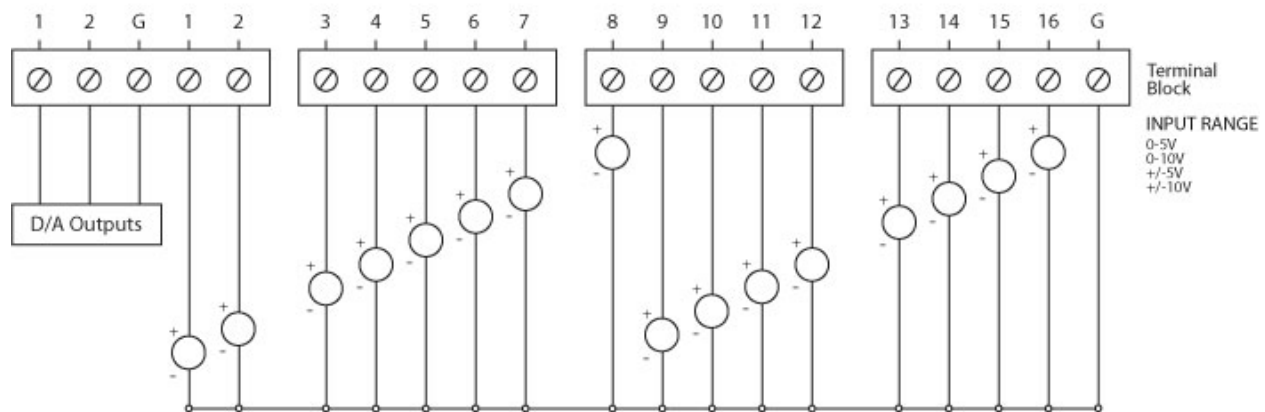

The Seal/O-470 can be configured for up to eight 12-bit differential A/D inputs. The inputs are not referenced to ground. The user selectable voltage ranges are 0-5V, 0-10V, +/-5V, and +/-10V.

Eight 12-Bit Differential A/D Inputs

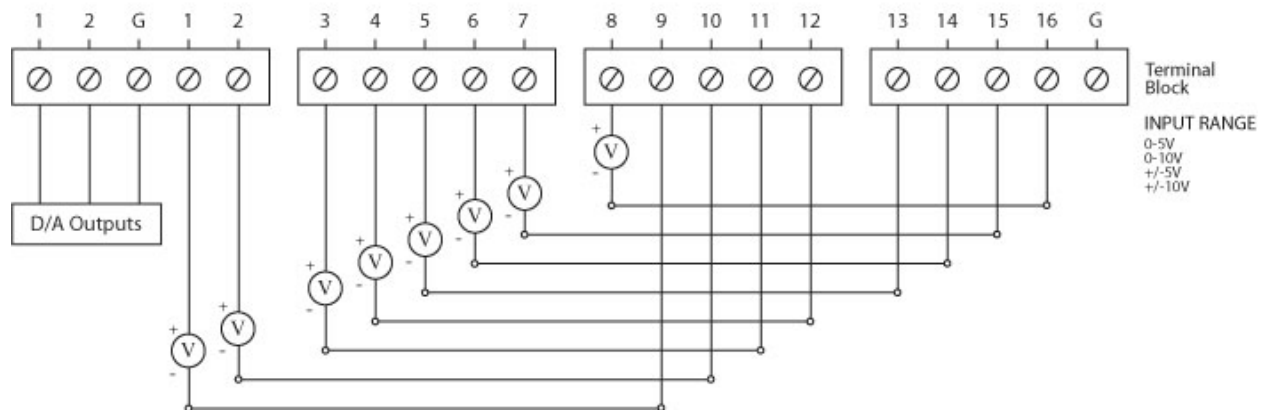

The Seal/O-470's A/D channels can also be configured to provide up to eight 12-bit current loop inputs. Each input has two terminals – one positive and one negative. The input current range is 0-20mA for interfacing commonly used 4-20mA devices. The dipswitches on the board must be properly configured for each current loop input.

Eight 12-Bit Current Loop A/D Inputs

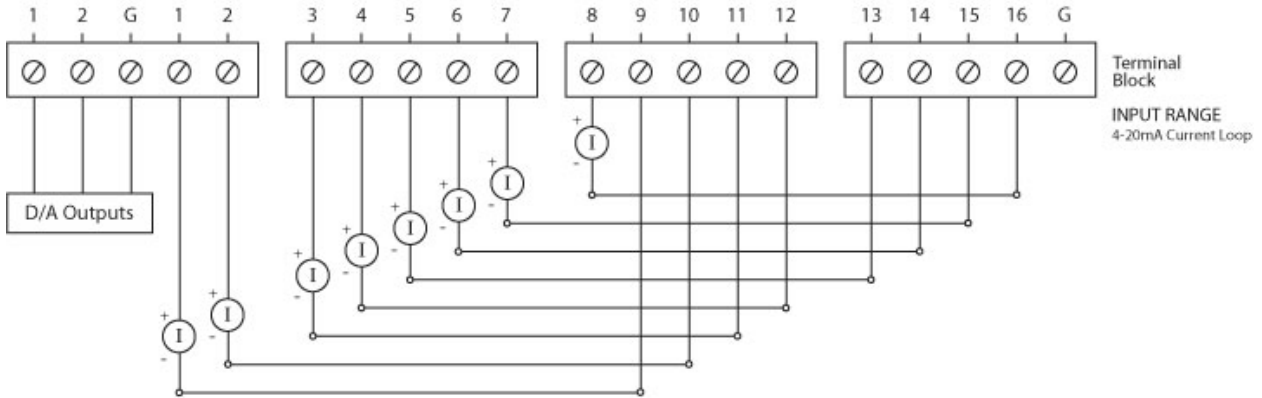

D/A Wiring Connections

The Seal/O-470 provides two 12-bit D/A output channels, configured for 0-10V. 0-5V mode requires different jumper settings on the board. Refer to the **Hardware Configuration** section of this manual for instructions on configuring the D/A jumpers.

The Seal/O-470 module's D/A output channels can be independently configured for 0-5V or 0-10V. The D/A outputs do not support negative voltages.

Two 12-Bit Single-Ended D/A Outputs

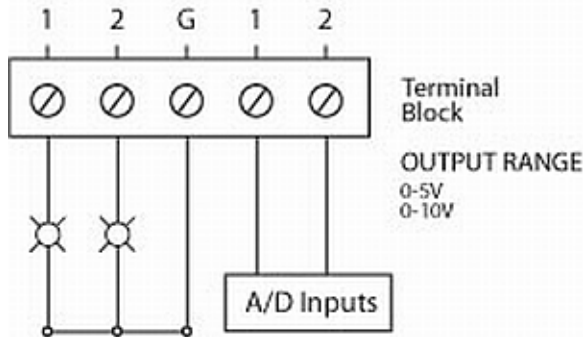

Digital I/O Wiring Connections

The SeaI/O-470 modules include eight optically isolated inputs that are arranged such that each group of four inputs shares a single common. The four I/O points and shared common are connected via a five-position removable screw terminal.

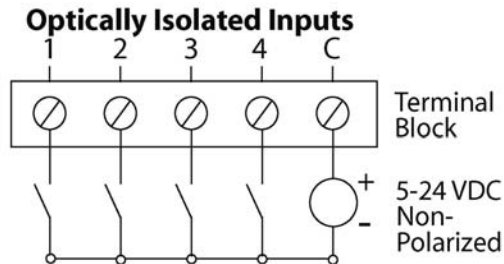

The SeaI/O-470 modules provide eight open-collector digital outputs. The outputs do not source any current and must be connected to an external power source, max 30VDC. The outputs act as a switch and the circuit is open until energized. When the output circuit is energized in software, the output sinks the current to ground, closing the circuit.

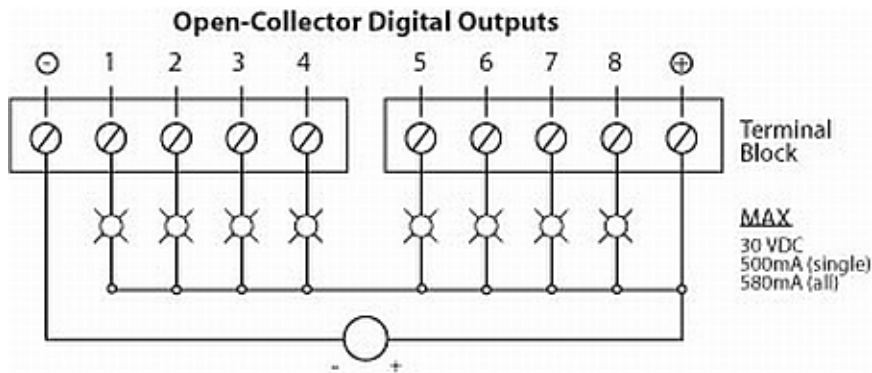

I/O Wiring – Seal/O-520 Modules

Optically isolated inputs are arranged such that each group of two shares a single common. The four I/O points and shared common are connected via a six-position removable screw terminal. Input voltage range is 5-30VDC. Like the inputs, each group of two Form C relays also shares a single common. The NC and NO contacts of each relay along with the commons are brought out via a six-position removable screw terminal.

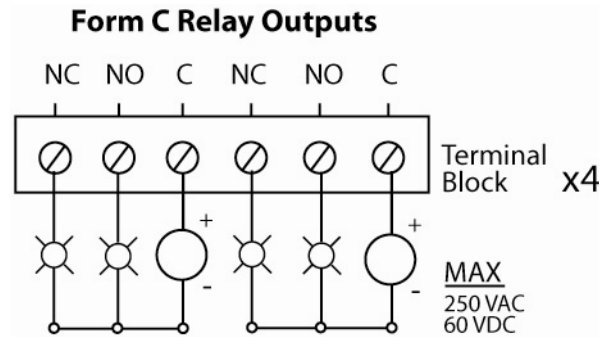
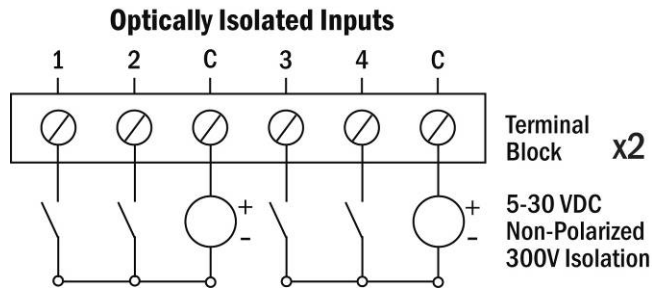

Connector Pin Outs

Seal/O (RS-232) S-Series Modules

Seal/O S-Series (RS-232) modules have an RJ45 connector on the front edge of the board. Each S-series module includes a kit (item# KT119) to convert the RJ45 RS-232 pin out to a standard DB9 RS-232 pin out. The kit ships with a DB-9F to RJ45 modular adapter (item# DB109) with RS-232 pin out and a standard 7' CAT5 patch cable (item# CA246). This kit allows Seal/O S-series modules to be easily connected to a standard DB9 RS-232 serial port. For other interfacing options, the RJ45 serial pin out is shown below.

RJ45 RS-232 (DCE) Serial Connector

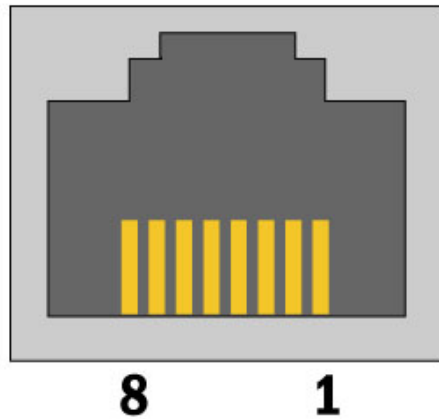

Pin Out

Pin #	Signal
1	TD
2	RD
3	CTS
4	5VDC Output
5	N/C
6	RTS
7	N/C
8	GND

NOTE: For Seal/O S-series modules, pin 4 of the RJ45 connector outputs 5VDC @300mA. This is useful for powering the wireless Bluetooth adapter (Sealevel Item# BT-SD100). This allows any Bluetooth capable host to access a Seal/O module as easily as communicating with a standard RS-232 serial port.



Accessories

Power Supplies

US Options

TR112 – 120VAC to 24VDC 250mA “Wall Wart” Power Supply with 1.3mm Plug (for single Seal/O module)

TR109 – 120VAC to 24VDC 500mA “Wall Wart” Power Supply with 1.3mm Plug (for multiple Seal/O modules)

TR108-US – 100-250VAC to 24VDC 36W 1.5A “Desktop” Power Supply with 1.3mm Plug, includes (CA248) Nema 5-15P 6’ US Power Cord

PS101 – 100-240VAC to 24VDC 7.5W 300mA DIN Rail Mount Power Supply (connects via screw terminals, no wire included)

PS103 – 100-240VAC to 24VDC 50W 2.1A DIN Rail Mount Power Supply (connects via screw terminals, no wire included)

International Options

TR108-AU - 100-250VAC to 24VDC 36W 1.5A “Desktop” Power Supply with 1.3mm Plug, includes (CA187) “AS 3112” 6’ Australian Power Cord

TR108-EC - 100-250VAC to 24VDC 36W 1.5A “Desktop” Power Supply with 1.3mm Plug, includes (CA188) “Schuko” 6’ Continental European Power Cord

TR108-UK - 100-250VAC to 24VDC 36W 1.5A “Desktop” Power Supply with 1.3mm Plug, includes (CA189) “BS 1363” 6’ UK Power Cord

TR108 – 100-250VAC to 24VDC 36W 1.5A “Desktop” Power Supply with 1.3mm Plug, requires IEC country-specific Power Cord

Cabling Options

CA239 – 5’ CAT5 RS-485 Interconnect Cable, used to connect Seal/O modules together in a stack (included in 4xxN Seal/O expansion modules)

CA246 – 7’ Blue Ethernet Patch Cable. Can be used to connect Seal/O Ethernet modules to a hub (included with 4xxE Seal/O Ethernet modules). Can be used to connect Seal/O RS-232 modules to both Sealevel and standard RS-232 serial ports (included with 4xxS Seal/O RS-232 modules as part of p/n: KT119). Optionally, it can be used as an RS-485 interconnect cable to cascade additional Seal/O modules via the RS-485 In/Out ports on the side of Seal/O modules

CA251 – 7’ Yellow Crossover Cable. Used to connect Seal/O Ethernet modules directly to a computer’s Ethernet port without having to go through a hub or switch

CA247 – 10’ Blue Ethernet Patch Cable. Can be used to connect Seal/O Ethernet modules to a hub, or can be used as an RS-485 interconnect cable to cascade Seal/O modules via the RS-485 In/Out ports

CA179 – USB 6’ A to B Cable (included with 4xxU Seal/O USB modules)

KT119 – RS-232 DB9/RJ45 Kit, includes (DB109) DB9F to RJ45 adapter with RS-232 pinout, and (CA246) 7’ CAT5 patch cable. For connecting Seal/O modules to both Sealevel and standard RS-232 serial ports (included with 4xxS Seal/O RS-232 modules)

KT120 – RS-422 DB9/RJ45 Kit, includes (DB110) DB9F to RJ45 adapter with RS-422 pinout, and (CA246) 7’ CAT5 patch cable. Optional accessory for connecting Seal/O modules to Sealevel RS-422 serial port products

KT121 – RS-485 DB9/RJ45 Kit, includes (DB111) DB9F to RJ45 adapter with RS-485 pinout, and (CA246) 7’ CAT5 patch cable. Optional accessory for connecting Seal/O modules to Sealevel RS-485 serial port products

Appendix A – How To Get Assistance

When calling for technical assistance, please have your user manual and current device settings ready. If possible, please have the device installed and ready to run diagnostics.

Sealevel Systems maintains a website on the Internet. Our homepage address is <http://www.sealevel.com>. The latest software updates and newest manuals are available via our FTP site that can be accessed from our home page. Manuals and software can also be downloaded from the product page for your device.

Sealevel Systems provides an FAQ section on our website. Please refer to this to answer many common questions. This section can be found at <http://www.sealevel.com/faq.asp>

Technical support is available Monday to Friday from 8:00 a.m. to 5:00 p.m. eastern time (UTC-6 hours). You can contact Technical Support via:

Phone: (864) 843-4343

Email: support@sealevel.com

Appendix B - CAD Drawing

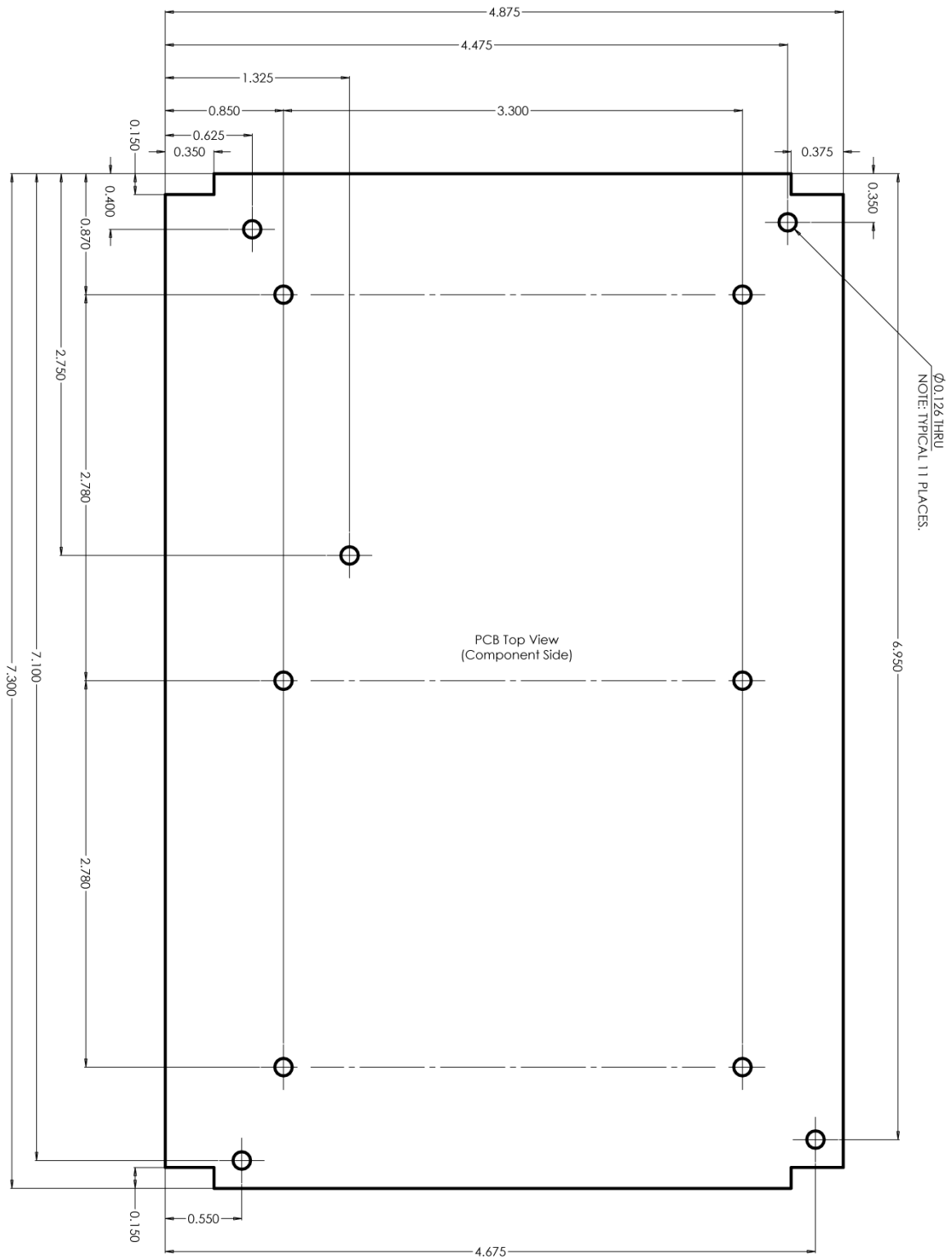

Appendix C – Compliance Notices

Federal Communications Commission Statement

FCC - This equipment has been tested and found to comply with the limits for Class A digital device, pursuant to Part 15 of the FCC Rules. These limits are designed to provide reasonable protection against harmful interference when the equipment is operated in a commercial environment. This equipment generates, uses, and can radiate radio frequency energy and, if not installed and used in accordance with the instruction manual, may cause harmful interference to radio communications. Operation of this equipment in a residential area is likely to cause harmful interference in such case the user will be required to correct the interference at the user's expense.

EMC Directive Statement



Products bearing the CE Label fulfill the requirements of the EMC directive (89/336/EEC) and of the low-voltage directive (73/23/EEC) issued by the European Commission.

To obey these directives, the following European standards must be met:

EN55022 Class A - "Limits and methods of measurement of radio interference characteristics of information technology equipment"

EN55024 – "Information technology equipment Immunity characteristics Limits and methods of measurement".

EN60950 (IEC950) - "Safety of information technology equipment, including electrical business equipment"

Warning

This is a Class A Product. In a domestic environment, this product may cause radio interference in which case the user may be required to take adequate measures to prevent or correct the interference.

Always use cabling provided with this product if possible. If no cable is provided or if an alternate cable is required, use high quality shielded cabling to maintain compliance with FCC/EMC directives.

Warranty



Sealevel's commitment to providing the best I/O solutions is reflected in the Lifetime Warranty that is standard on all Sealevel manufactured products. We are able to offer this warranty due to our control of manufacturing quality and the historically high reliability of our products in the field. Sealevel products are designed and manufactured at its Liberty, South Carolina facility, allowing direct control over product development, production, burn-in and testing.

Sealevel Systems, Inc. (hereafter "Sealevel") warrants that the Product shall conform to and perform in accordance with published technical specifications and shall be free of defects in materials and workmanship for life. In the event of failure, Sealevel will repair or replace the product at Sealevel's sole discretion. Failures resulting from misapplication or misuse of the Product, failure to adhere to any specifications or instructions, or failure resulting from neglect or abuse are not covered under this warranty. Warranty service is obtained by delivering the Product to Sealevel and providing proof of purchase.

NOTE:  **Return authorization must be obtained from Sealevel Systems before returned merchandise will be accepted. Authorization is obtained by calling Sealevel Systems and requesting a Return Merchandise Authorization (RMA) number.**

The Customer agrees to insure the Product or assume the risk of loss or damage in transit, to prepay shipping charges to Sealevel, and to use the original shipping container or equivalent. Warranty is valid only for original purchaser and is not transferable.

Sealevel Systems assumes no liability for any damages, lost profits, lost savings or any other incidental or consequential damage resulting from the use, misuse of, or inability to use this product. Sealevel Systems will not be liable for any claim made by any other related party.

This warranty applies to Sealevel manufactured Product. Product purchased through Sealevel but manufactured by a third party will retain the original manufacturer's warranty.

Sealevel Systems, Incorporated
2779 Greenville Highway
P.O. Box 830
Liberty, SC 29657 USA
(864) 843-4343 FAX: (864) 843-3067
www.sealevel.com
email: support@sealevel.com

Technical Support is available Monday - Friday from 8 a.m. to 5 p.m. Eastern time.

Trademarks

Sealevel Systems, Incorporated acknowledges that all trademarks referenced in this manual are the service mark, trademark, or registered trademark of the respective company.